

2ch NIM V/F CONVERTER

N2VF-01

(2348 Ver. 3)

SER _____



APPLICATION OF ELECTRONIC DEVICES

TSUJI ELECTRONICS CO., LTD

3739 Kandatsu-machi Tsuchiura-city
Ibaraki-Pref 300-0013 Japan

Phone +81-(0)29-832-3031
fax +81-(0)29-832-2662

URL <http://www.tsujicon.jp>
E-mail info2@tsuji-denshi.co.jp

NIM V-F CONVERTER USER'S MANUAL

Type N2VF-01

A V-F Converter constructed in a NIM-1 UNIT case has two channels outputs and include a four stage amplification factor switch and a polarity selector switch. In addition, with over range and polarity displayed, V-F conversion is always performed at the optimum conditions. The over range signal is output as a transistor open-collector signal which can be used as a warning. The DC amplifier can be used under isolated (floated) condition from the NIM power source, providing higher noise tolerance.

1. Specification

- | | |
|------------------------|--|
| 1) Gain | 1MHz/10V , 1MHz/1V , 1MHz/100mV, 1MHz/10mV |
| 2) Input Voltage | 0 ~ 10V (Acceptable input $\pm 100V$ Max) |
| 3) Input Resistance | 1M or more |
| 4) Output | TTL level (or out to 50 by jumper pin) positive logic 0 ~ 1MHz |
| 5) Conversion Accuracy | $< \pm 0.02\%/FS$ |
| 6) Power Supply | +6V about 1300mA (From NIM Connector) |
| 7) Case | NIM-1 |

2. Panel lay out

1) Front panel layout

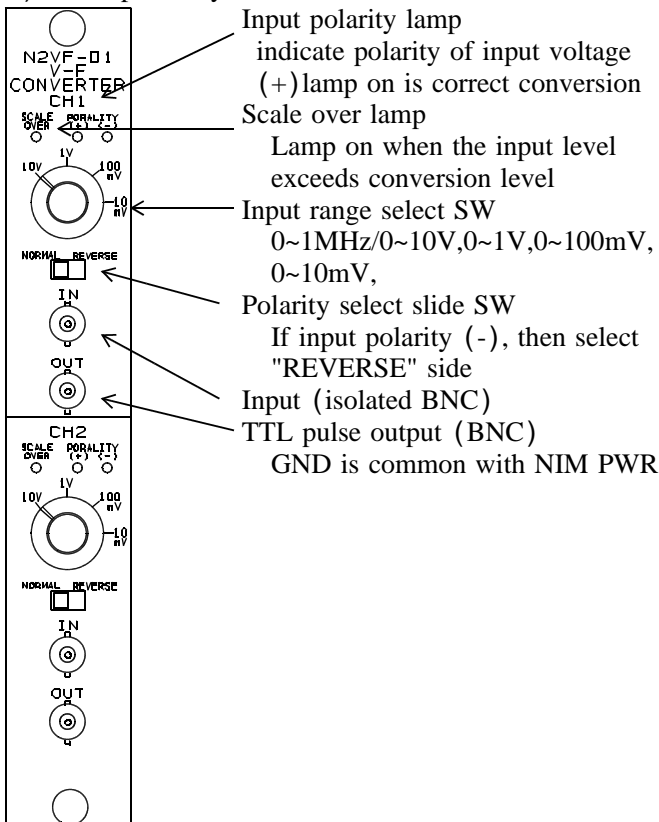

2) Rear panel layout

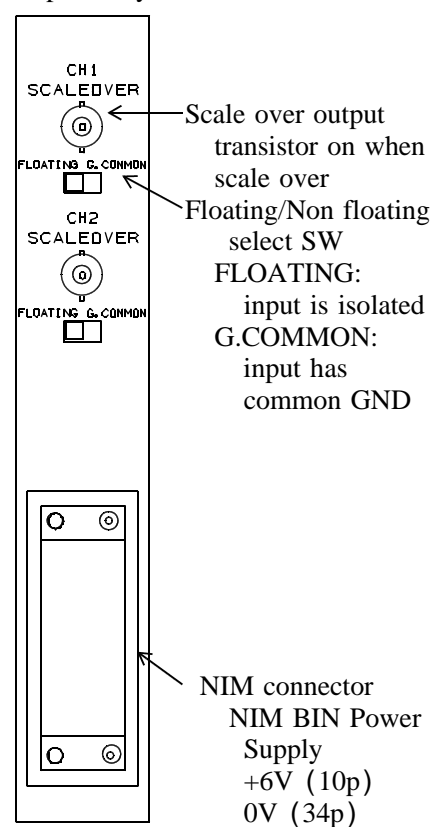

3. Circuit of input/output

1) Voltage input

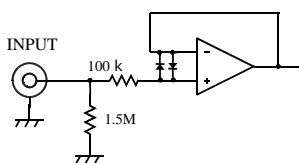

2) Pulse out (*)

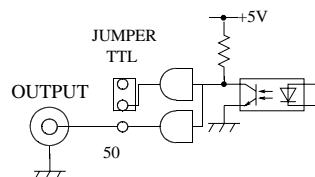

3) Scale over out

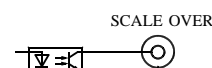

(*) Output level exchange (TTL 50) is enable by opening the left side panel and moving jumper pins (JP3 for ch1, JP4 for ch2) those are located on the front panel side of the board. They are set to TTL level side as defaults.