

16CH STEPPING MOTOR CONTROLLER
PM16C-04XDL
LOCAL CONTROL USER'S MANUAL

2735, 2736 (rev 3/2010.09.15)



APPLICATION OF ELECTRONIC DEVICES

TSUJI ELECTRONICS CO.,LTD

3739 Kandatsu-machi Tsuchiura-city
Ibaraki-Pre 300-0013 Japan
Phone +81-(0)29-832-3031
Fax +81-(0)29-832-2662
URL <http://www.tsujicon.jp>
E-mail info2@tsuji-denshi.co.jp

CONTENTS

1. Abstract	1
1) Features	1
2) The architecture of this unit	2
3) The system of operation	3
2. Front key switches	3
3. Screen of operation	5
3.1 Initial screen	5
3.2 Motor access screen	6
3.3 Mode set screen	7
3.4 The way of data set in mode set screen	7
4. Set-up Operation	7
4. 1 P1 :Motor activation, limit switch setting	8
4. 2 P2 :Digital limit switch setting	9
4. 3 P3 :Speed setting	10
4. 4 P4 :Acceleration and deceleration setting	10
4. 5 P5 :REL,ABS,SCAN data setting	11
4. 6 P6 :Home position setting	12
4. 7 P7 :Timing Out setting	13
4. 8 P8 :Timing Out channel setting	14
4. 9 P9 :Parameters of remote mode setting	14
4. 10 P10:LAN setting	15
4. 11 P11:Program version change, and return time from mode set screen	15
5. Further Information	16
5. 1 Set the motor speed	16
(1) Acceleration and deceleration setting "Const"	16
(2) Acceleration and deceleration setting "Trape"	16
(3) Acceleration and deceleration setting "Schar"	16
5. 2 Timing chart of Timing out port	17
(1) Gate mode setting	17
(2) Pulse mode setting	17
5. 3 Hand box control	18
5. 4 Setting the origin of home position	18
(1) At the beginning	19
(2) Selection of detecting ways	20

6.	Rear panel	22
6. 1	Appearance of rear panel	22
6. 2	Connection of external devices	23
7.	Acceleration and Deceleration Rate	24
8.	Performance and specifications	25

PM16C-04XDL USER'S MANUAL IN LOCAL MODE

1. Abstract

PM16C-04XDL is the successor unit to PM16C-02N, PM16C-02Z, PM16C-04, PM16C-04S. It's compatible with usage and communication commands.

It's improved local operation comparing with low cost PM16C-04XD unit.

These are the strong points comparing with PM16C-04XD.

- ① Expand the count pulse step bits, 24bits to 32bits.
Numerical range is $-2, 147, 483, 647 \sim +2, 147, 483, 647$.
(In case of type PM16C-04: $-8, 388, 607 \sim +8, 388, 607$)
- ② Expand the out put pulse frequency 1PPS \sim 5MPPS .
(In case of type PM16C-04: $1 \sim 800, 000$ PPS)
- ③ Expand the range of acceleration and deceleration range is $1048.56 \sim 0.0125$ ms/1000PPS.
(In case of type PM16C-04: $1000 \sim 0.05$ ms/1000PPS)
- ④ It's available trapezoid and "S" character acceleration and deceleration activation.
- ⑤ Easy connection according to serial CH0 to CH15 connector allocation.
- ⑥ Contains the output connector which activates external devices.
It outputs the trigger pulse or gate pulse at the arbitrary points and intervals.
- ⑦ It's available to change firmware ROM according to communication line.
- ⑧ IP address setting can be changed by this one.
- ⑨ The case size is compact 2U size (height is 88mm). Old one is 3U.
- ⑩ The output format of 2 pulse or 1 pulse is selectable for each channel.
(The type PM16C-04 is selectable for each window.)
- ⑪ Parameter setting is easy according to flat panel and wide LCD screen.

1) Features

These points are useful as before.

- ① It controls 16 pulse motors.
*Each characteristics (HSPD, MSPD, LSPD, RATE, LMSW, DGLS) is available for each channel.
- ② Maximum 4 units motors are activate at same time.
- ③ It activates absolute position movement, relative position movement and continuous movement according to 3 kinds of acceleration and deceleration movement.
3 kinds of movement is constant, trapezoid and "S" character acceleration and deceleration activation.
- ④ About the way of motor stopped motion
In case of limit switch on.
In case of home position limit switch on. (when detecting home position.)
In case of digital limit switch on.
in case of Button "STOP" on.
To above motor stop case, deceleration stop or emergency stop way is selectable.

⑤ Hand box operation (Optional unit)

It's possible to control four motors by wired remote control box.

It's possible to change the speed (High, Middle, low) by this box.

⑥ The way of control this unit is local control and remote control.

Local mode is front panel operation and remote control is via communication line.

Communication line is as follows and selectable.

1. GP-IB communication
2. RS232C communication
3. LAN(Ethernet) communication

2) The architecture of this unit

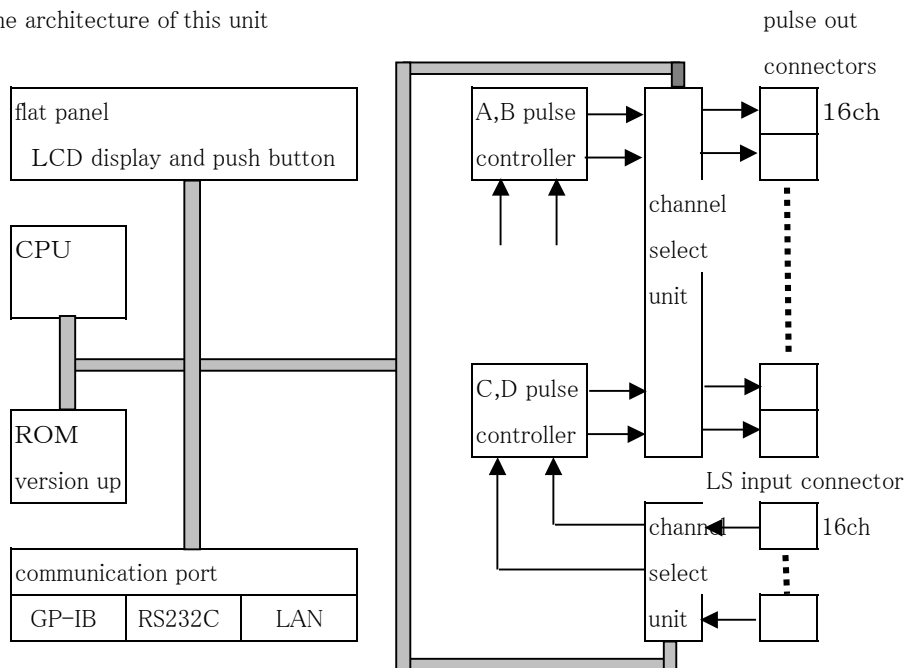

3) The system of operation

- Operation {
- Local operation It's possible to control this unit and setup initial data for each channel.
Hand box controller is also available.
 - Remote operation Controlled by commands of outside devices.

It's selectable by GP-IB or RS-232C or Ethernet communication.

The detail of remote control is by another manual.

It's "REMOTE CONTROL USER'S MANUAL".

2. Front key switches

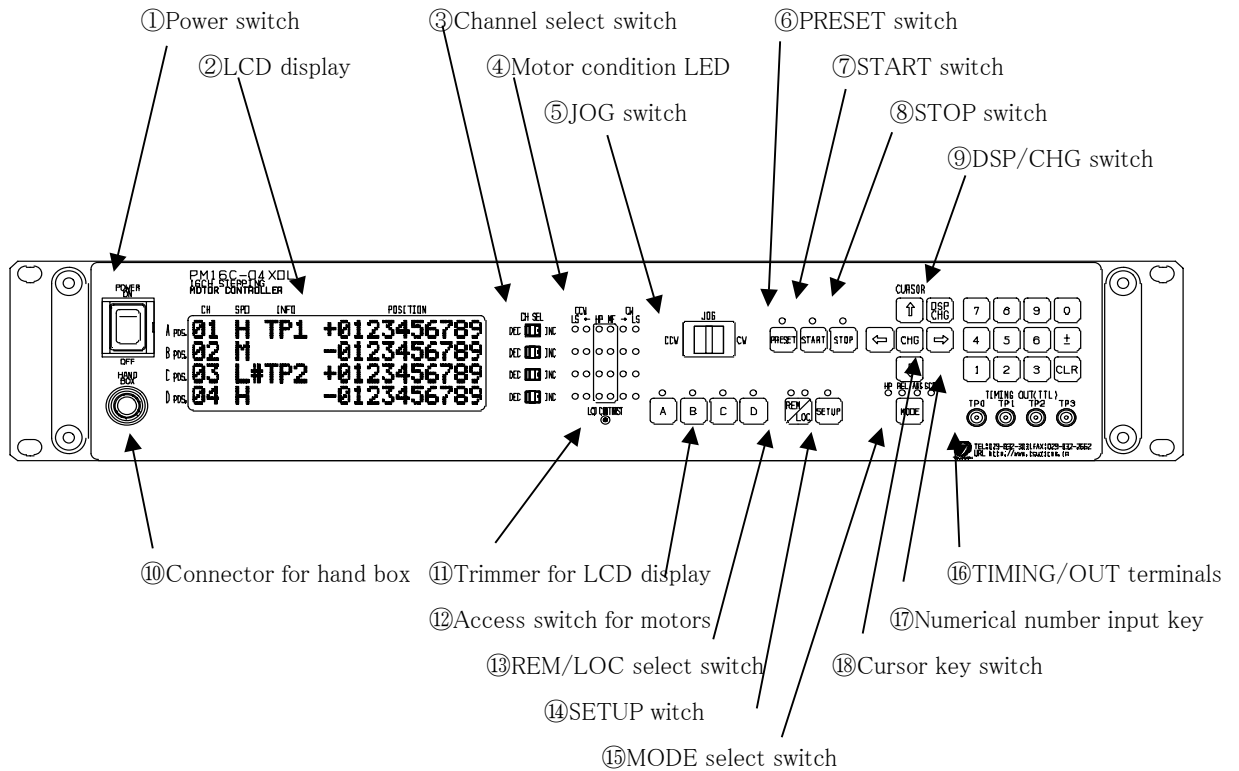



Fig1 Front panel

NO.	Parts name	Functions
①	Power switch	Power on and off switch to the unit.
②	LCD display	Wide range high brightness LCD display. 20 characters × 4 lines. The brightness is controlled by ⑪ Trimmer for LCD display. LCD display appears three functions. Motor access screen, mode set screen, data set screen.
③	Channel select switch	Any 16 motor channel is allocated to A,B,C,D channel. The selection of motor channel is incremental format such as 0CH-1CH-2CH....., and decrement format such as CH0-CH15-ch14.....by this switch.

④	Motor condition LED	When in setup mode, setup channel NO is changeable by A pos channel select switch. These LED appear the state of A,B,C,D motors. Details are in Fig 2.
⑤	JOGスイッチ	It starts JOG operation. CW and CCW operation is done by this one. It starts and stops just JOG set pulse. When it pushed more than 0.4 seconds, motor acts continuous moving mode. And in setup mode, the screen of setup function is changeable by this one.
⑥	PRESET switch	When in ⑮MODE select switches in SCAN mode, preset value is stored to pulse position data.
⑦	START switch	Set the motors of selected channels activate.
⑧	STOP switch	Set the motors of selected channels stopped.
⑨	DSP/CHG switch	It changes motor access screen and mode set screen. When in mode set screen, there is no operation between some seconds, the screen is to motor access screen type.
⑩	Connector for hand box	Connector for hand box controller.
⑪	Trimmer for LCD display	The brightness of LCD is controlled by this trimmer by + screw driver.
⑫	Access switch for motors	It possible to active or non-active for each A,B,C,D channels.
⑬	REM/LOC select switch	It possible to change remote or local mode. When put on this switch mode is changed alternately.
⑭	SETUP witch	This switch is available when in local mode. When in this mode motor access parameters are determined for each channel.
⑮	MODE select switch	It changes the active mode for select motor channels. The confirmation of active mode is done by ④Motor condition LED. It changes H.P>>REL>>ABS>>SCAN>>H.P in sequential.
⑯	TIMING/OUT terminals	Pulse signal goes on according to pulse position data for each channel. Signal of TTL level goes from this LEMO type connectors. Each A,B,C,D channel is to terminal TP1,TP2, TP3,TP4. (Ver1.10) About details of timing out, see chap.5.1 Timing Out timing set chart.
⑰	Numerical number input key	Numerical input key <input type="text" value="0"/> ~ <input type="text" value="9"/> + or - change key <input type="text" value="±"/> data clear key <input type="text" value="CLR"/> When in change channel NO <input type="text" value="±"/> Decrement channel NO <input type="text" value="CLR"/> Increment channel NO

⑱	Cursol key switch		<p>Cursor position is determined by these key switches.</p> <p> Set data is changeable by this one.</p>
---	-------------------	--	--

Details of ④Motor condition LED

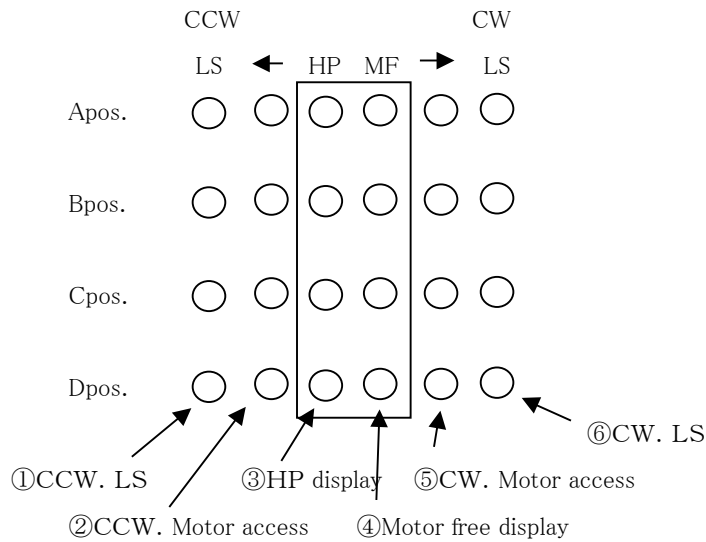

Fig 2. Motor condition display LED

NO.	Parts name	Functions
①	CCW. LS(limit switch) :red	When CCW direction limit switch goes on, this LED turn on continuously. When CCW direction digital limit switch goes on, this LED turn on and off interval 0.4 second.
②	CCW. Motor access:green	When CCW direction motor goes on, this LED turn on.
③	H. P(Home position) limit switch:yellow	When H.P limit switch goes on, this LED turn on.
④	Motor free display:yellow	When motor hold off function goes on, this LED turn on.
⑤	CW. Motor access:green	When CW direction motor goes on, this LED turn on.
⑥	CW. LS(limit switch) :red	When CW direction limit switch goes on, this LED turn on continuously. When CW direction digital limit switch goes on, this LED turn on and off interval 0.4 second.

3. Screen of operation

3. 1 Initial screen

*	*	*	*	P	M	1	6	C	-	0	4	X	D	L	*	*	*	*	*
S	T	E	P	P	I	N	G			M	O	T	O	R					
C	O	N	T	R	O	L	L	E	R		V	e	r	<	1	.	0	9	>
T	S	U	J	I	-	D	E	N	S	H	I		C	o	.	L	T	D	,

Initial screen when power on.

Software version is displayed.

3. 2 Motor access screen

This is normal screen when in motor access mode.

From the top position, pulse out channel A, B,C, D is allocated.

Any CH0 ~ CH15 channel number is allocated for each A, B, C, D channel.

And each channel is set to activate or non-activate for each channel.

When in active mode motor could be activate by JOG switch and START switch.

Each parameter set is don by cursor position.

Cursor position is displayed by mark .

A.pos	0	0	H	T	P	0	0	1	2	3	4	5	6	7	8	9		
B.pos	0	1	M	#	T	P	1	-	0	1	2	3	4	5	6	7	8	9
C.pos	0	2	L	#	T	P	2	-	0	1	2	3	4	5	6	7	8	9
D.pos	1	5	L	▲	T	P	3	0	1	2	3	4	5	6	7	8	9	

- ①Displays the motor channel ②Speed of motor is set for each channel.
- ③Set timing port to ready ④Select port NO of timing out
- ⑤It means the pulse position. Not allowed to write.

ITEMS	DISPLAY	OPERATION
①Set the motor channel NO	00 ~ 15	It's determined by numerical key switches. Or ± Increment the channel NO. CLR Decrement the channel NO. OR set the channel NO directry by channel select switch. Channel NO is not allowed to same before NO. When you set the same NO twice, the number is blinking disp. When you set it by channel select switch, the same number is skipped.
②Set the motor speed	H:High range of speed M:Middle range of speed L:Low range of speed	It's possible to change the motor speed by CHG switch. Each step of speed H,M,L is set by SETUP mode for each channel.
③Select Motor Out mode of motor channel #:Timing Out Ready	00 H(A) TP0 00 H# TP0	Position (A) is change as (sp)>>#>>(sp)>>...by switch CHG When in mark # , timing out port is ready. When in mark (sp) , timing out port is not ready. Only in timing out ready mode, timing out signal goes on depend on the pulse position. (Details are in chap5.2 Timing out mode)
④Selection of output port for each channel		Timing out port 0,1,2,3 is allocated to each motor access channel A,B,C,D. It's rigid to software version 1.1)
⑤Appears the pulse position	MAX ±2,147,483,647	It appears the pulse position.

3.3 Mode set screen

"Motor set screen" or "Mode set screen" is selectable by DSP/CHG button.

When in this mode, relative move step pulse, absolute move position data, preset position value, and home position value data are checked and changeable.

A. pos	0	0		H		R	E	L			0	1	2	3	4	5	6	7	8	9
B. pos	0	1		M		R	E	L	-		0	1	2	3	4	5	6	7	8	9
C. pos	0	2		L	#	R	E	L	-		0	1	2	3	4	5	6	7	8	9
D. pos	1	5		L		R	E	L			0	1	2	3	4	5	6	7	8	9

There are four active mode in PM16C-04XDL. Each mode is selected by mode switch.

This active mode is as common for selected active channels.

- (1) H.P Mode It's useful to detect origin point of pulse count for each channel.
(Details are in chap5.3 Setting the origin of home position)
- (2) REL Mode Relative value move step pulse mode.
By key switch "STAT" + "CW, CCW" switch on , motor moves by the amount of preset pulse value only one click.
In midstream, this motion is stopped by "STOP" switch or limit switch.
- (3) ABS Mode Absolute value move pulse mode.
By "START" button, motor moves to preset pulse position.
In midstream, this motion is stopped by "STOP" switch or limit switch.
- (4) SCAN Mode Continuous move mode to CW, CCW direction.
By key switch "STAT" + "CW, CCW" switch on , motor moves to dedicated direction continuously.
In midstream, this motion is stopped by "STOP" switch or limit switch.

3.4 The way of data set in mode set screen

In mode set screen, related pulse count value is preset by numerical keys for each mode.

If you change these value, set cursor to desired channel position and as these procedures.

- If you change the sign of number, push key.
- If you clear the number, push key.
- If you enter the number, enter numerical key from top of it.
When you move the cursor position, you could set the number from top of it.
- If you enter minus value, you could change the sign of it by key in midstream.
- About pulse number, there is no sign + mark in display.
- While you enter key switch, the number display is zero suppress display mode, but the cursor move to another point, previous number is decided so display of it is with zero.
- In home position mode, when there is no memorized home position data for channel, display in mode set screen is "NO_HOME POS".

In this case you couldn't enter home position data by key switch.

Only in case of memorized home position data exist, this number is changeable.

* When in SETUP mode, in case of there is no memorized data, you could set the home position by entering numerical position data.

This way of entering numerical number is adapted to chap 4 SETUP SCREEN.

4. Set-up Operation

If you push "SETUP" switch, It's possible to set the parameters for each channel in local mode.

You can enter SETUP mode from "Motor access screen" or "Mode set screen".

When in SETUP mode, push "SETUP" switch then you can go back to "Motor access screen".

⑤Enable or disable limit switch action for direction CW. Contact setting and present state.	ENA/DIS	It's changed by <input type="checkbox"/> CHG switch.
	N.O(Normaly Open)	It's changed by <input type="checkbox"/> CHG switch.
⑥Enable or disable limit switch action for direction CCW. Contact setting and present state.	N.C(Normaly Close)	Present state: non-active
	" "	Present state: active
⑥Enable or disable limit switch action for direction CCW. Contact setting and present state.	" "	Present state: non-active
	"□"	Present state: active

Note 1: Motor hold off function is cut off the power line when motor stopped.
When this function is "ENA", the power line is cut off whe motor stopped.

4. 2 P2 :Digital limit switch setting

①Display and change SETUP channel 0-15

②Enable or disable digital limit switch action.

Direction CW,CCW is same.

C	H	:	0	0		D	I	G	I	T	A	L	L	S		P	2		
C	W	:	D	I	S			0	1	2	3	4	5	6	7	8	9	-	
C	C	W	:	D	I	S		-	0	1	2	3	4	5	6	7	8	9	□
			B	A	C	K	L	A	S	H	:	<	+	9	9	9	9	>	

③Display and set the digital limit switch value for CW、CCW direction, and present state.

④Backlash data

ITEMS	DISPLAY	OPERATION
①Display and change SETUP channel 0-15	00~15	See 4.1 P1
②Enable or disable digital limit switch action.	ENA/DIS	It's changed by <input type="checkbox"/> CHG switch. This function is same for CW,CCW.
③Display and set the digital limit switch value for CW、CCW direction, and present state.	MAX ±2,147,483,647	See 3.4 Enter numerical key switch.
④Backlash data	Only displayed data	It's possible to set value in remote mode not in local mode.

4.3 P3 :Speed setting

①Display and change SETUP channel 0-15

②Set "High" speed value. Unit:pps

③Set "Middle" speed value. Unit:pps

④Set "Low" speed value. Unit:pps

C	H	:	0	0					S	P	E	E	D	(p	p	s)		P	3
H	:	5	0	0	0	0	0	0	0	0											
M	:	5	0	0	0	0	0	0	0	0			J	O	G	:	9	9	9	9	
L	:	5	0	0	0	0	0	0	0	0			R	A	T	E			1	1	5

⑤Set "JOG STEP" value

⑥Set "Rate Data" value

ITEMS	DISPLAY	OPERATION
①Display and change SETUP channel 0-15	00~15	See 4.1 P1
②Set "High" speed value. Unit:pps	0~ 9,999,999	Set by numerical key switch.
③Set "Middle" speed value.	0~ 9,999,999	Set by numerical key switch.
④Set "Low" speed value.	0~ 9,999,999	Set by numerical key switch.
⑤Set "JOG STEP" value	0~ 9,999	Set pulse steps in JOG operation It's one step pulse numbers.
⑥Set "Rate Data" value	0~ (MAX) 115	Set by numerical key switch.

4.4 P4 :Acceleration and deceleration setting

①Display and change SETUP channel 0-15

②Selection of acceleration and deceleration format

C	H	:	0	0					A	C	C	&	S	T	O	P				P	4
A	C	C	_	M	O	D	E	:					T	r	a	p	e				
S	T	O	P	_	M	O	D	E	L	.	S	:	S	L	O	W					
									P	.	B	:	F	A	S	T					

③Selection of stop mode: In case of limit switch

④Selection of stop mode: Incase of push bottun.(Panel operation)

ITEMS	DISPLAY	OPERATION
①Display and change SETUP channel 0-15	00~15	See 4.1 P1
②Selection of acceleration and deceleration format	Const (constant acceleration drive) Trape (trapezoidal form acceleration drive) Schar ("S" character form acceleration drive)	It's changed by CHG switch.

4. 6 P6 :Home position setting

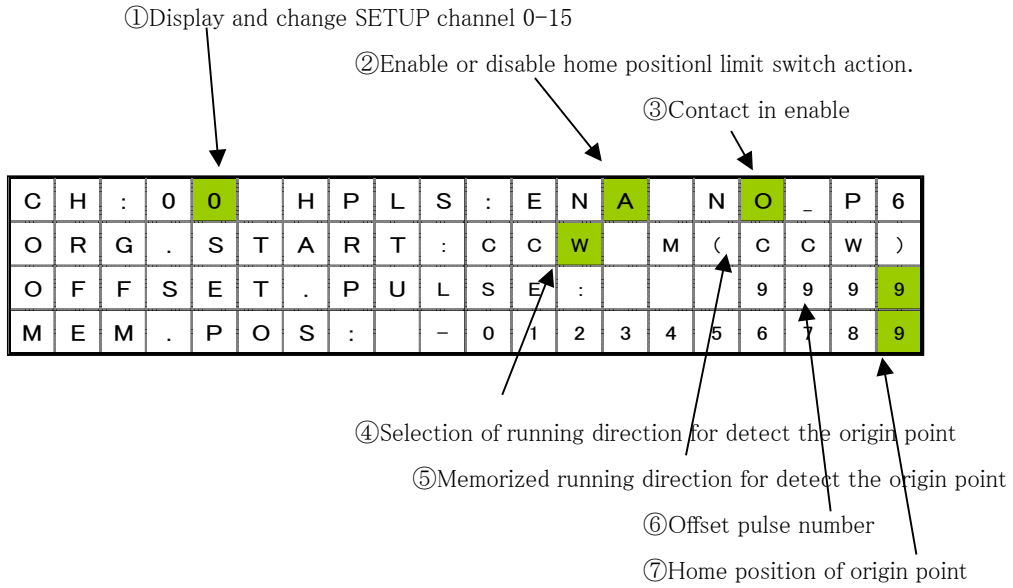

ITEMS	DISPLAY	OPERATION
①Display and change SETUP channel 0-15	00~15	See 4.1 P1
②Enable or disable home position limit switch action.	ENA/DIS	It's changed by <input type="button" value="CHG"/> switch.
③Contact in enable	N.O/N.C Normaly Open / Normaly Close	It's changed by <input type="button" value="CHG"/> switch.
④Selection of running direction for detect the origin point	CW/CCW	It's changed by <input type="button" value="CHG"/> switch.
⑤Memorized running direction for detect the origin point	CW/CCW	Only display the direction. Not impossible to set.
⑥Offset pulse number	9999	Set by numerical key switch.
⑦Home position of origin point	0~±2,147,483,647	When origin point had been set, this position data is displayed. When origin point hadn't been set, display is "NO H.P.". When display is "NO H.P.", enter <input type="button" value="CHG"/> key, then enter numerical key you can set home position data . To cancel H.P data, enter <input type="button" value="CHG"/> key, then "NO H.P." displayed.

4.7 P7 :Timing Out setting

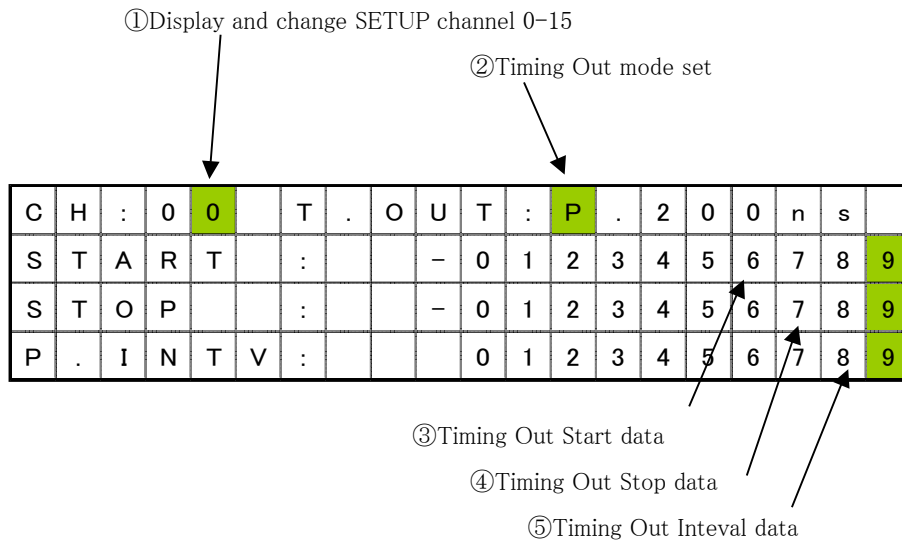

ITEMS	DISPLAY	OPERATION
①Display and change SETUP channel 0-15	00~15	See 4.1 P1
②Timing Out mode set	DIS GATE PULSE 200ns PULSE 10us PULSE 100us PULSE 1ms	It's changed by <input type="checkbox"/> CHG switch. Disable: Timing Out GATE mode output. Signal out between START and STOP. PULSE mode output Pulse Intervals are as these. Pulse width is 200ns>>10us >>100us>>1ms It's changed by <input type="checkbox"/> CHG switch.
③Timing Out Start Position	0~±2,147,483,647	Set by numerical key switch.
④Timing Out Stop Position	0~±2,147,483,647	Set by numerical key switch. Related to GATE mode output.
⑤Timing Out Interval Pulse	0~ 2,147,483,647 unsigned number	Set by numerical key switch. Pulse interval in pulse mode output

About the details of Timing Out, see chap5.1 Timing chart of Timing out port.

4.8 P8 :Timing Out channel setting

This set screen is not available in software version V1.10.

T	I	M	I	N	G				T	P	0	:	C	H	*	*		P	8
O	U	T							T	P	1	:	C	H	*	*			
S	E	T	T	I	N	G			T	P	2	:	C	H	*	*			
R	E	S	E	R	V	E	D		T	P	3	:	C	H	*	*			

In software version V1.10, channel number and timing ou port number is rigid.

TP0	Timing Out Port0	A.Pos set channel
TP1	Timing Out Port1	B.Pos set channel
TP2	Timing Out Port2	C.Pos set channel
TP3	Timing Out Port3	D.Pos set channel

4.9 P9 :Parameters of remote mode setting

R	E	M	O	T	E		C	O	N	T	R	O	L					P	9
R	S	-	2	3	2	C		B	.	R	A	T	E	:	3	8	4	0	0
G	P	I	B		A	D	D	R	E	S	S	:						3	1
H	A	N	D		B	O	X		C	O	N	T	:	0	4	T	Y	P	E

①RS-232C baud rate set

②GPIB address set

③Hand box type set

ITEMS	DISPLAY	OPERATION
①RS-232C baud rate set	1200 >> 2400 >> 4800 >> 9600 >> 19200 >> 38400 >> 1200.....	It's changed by <input type="button" value="CHG"/> switch. Baudrate data is 1200~38400(bps)
②GPIB address set	It's available 2-31	Set by numerical key switch. Or <input type="button" value="±"/> Address increment <input type="button" value="CLR"/> Address decrement
③Hand box type set	Type02/ Type04/ Type16	It's changed by <input type="button" value="CHG"/> switch. Type02:active A,B 2 channels Type04:active 4 channels Type16:active 16 channels

* About the details of hand box, see chap5.2 Hand Box Control.

4. 10 P10:LAN setting

L	A	N	S	E	T	T	I	N	G					P	1	0	
M	A	C	:	<	1	A	2	B	3	C	4	D	5	E	6	F	>
I	P	:	1	9	2	.	1	6	8	.	0	0	1	.	0	5	5
P	O	R	T	.	N	O	:						1	0	0	0	1

①MAC address

②IP address

③PORT number

ITEMS	DISPLAY	OPERATION
①MAC address	12 characters	It's MAC address inside LAN module
②IP address	3 digit 4 data Maximum:255 (Hex (FF))	Set by numerical key switch.
③PORT number	Maximum:32767 (Hex (7FFF))	Set by numerical key switch.

(NOTE) When you change IP ADDRESS or PORT NO, it's need to put on power switch.

4. 11 P11:Program version change, and return time from mode set screen

P	R	O	G	R	A	M	C	H	A	N	G	E			P	1	1	
					N	E	W		v	e	r		<	1	.	2	9	>
D	S	P	/	C	H	G		R	E	T	U	R	N		:	9	9	s
T	S	U	J	I	-	D	E	N	S	H	I	C	o	.	L	T	D	,

①To change software version

②Return time from mode set screen

ITEMS	DISPLAY	OPERATION
①To change software version	NEW / OLD	It's changed by <input type="checkbox"/> CHG switch. Details are in "PM16C-04XDL REMOTE CONTROL USER'S MANUAL".
②Return time from mode set screen	00 01 ~ 99 seconds	00: No return function. 01-99: When no key touch time continued, "Mode set screen" back to "Motor access screen" automatically.

(NOTE) IN PM16C-04XDL, "Motor access screen" is normal display.

When push DSP/CHG key, screen changed to "Mode set screen".

This screen is convenient to check and change channel parameters.

But when no key touch time continued for some seconds, "Mode set screen" back to "Motor access screen" automatically.

When you don't need this change, you set 00 time.

5. Further Information

To use PM16C-04XDL correctly, following information help you to use one.

5.1 Set the motor speed

The temporal characteristic of the setting speed "H, M, and L" becomes a temporal characteristic shown in following figure in association with the selection of the acceleration and deceleration setting mode.

(1) Acceleration and deceleration setting "Const (constant acceleration drive)"

Acceleration and deceleration is not set.

Coution: The motor may not start is the speed is too large.

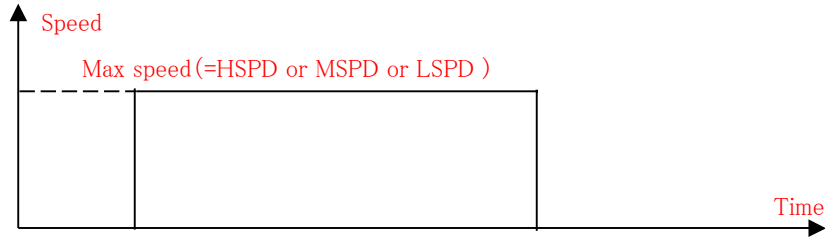

(2) Acceleration and deceleration setting "Trape (trapezoidal form acceleration drive)"

Start speed is "LSPD".

Coution: Large value of "LSPD" may not make smooth start of the motor.

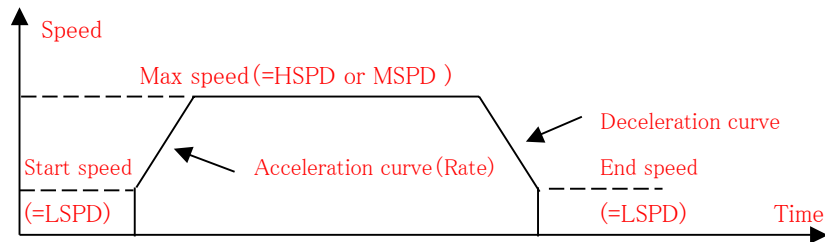

(3) Acceleration and deceleration setting "Schar("S" character form acceleration drive)"

Start speed is "LSPD".

Coution: Large value of "LSPD" may not make smooth start of the motor.

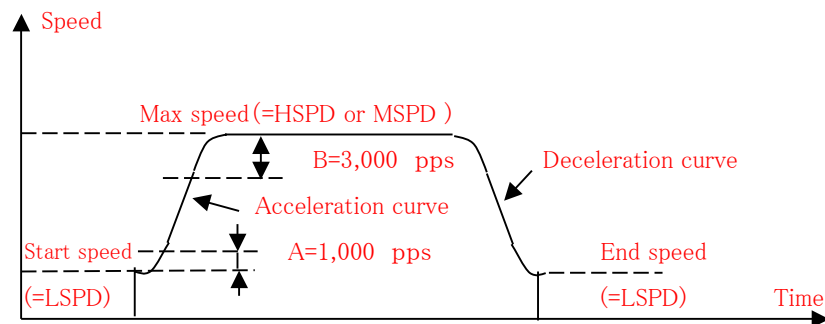

Increase speed A=1,000pps, Decrease speed B=3,000pps

Smooth curve is "HSPD <= LSPD + 4,000pps" a conversion.

5. 2 Timing chart of Timing out port

Pulse access channel output signals(TTL level) according to each channel pulse position.

This is called timing mode.

There are two ways of timing output. One is "Gate mode" another is "Pulse mode".

This mode is available in remote and local mode. The way of setting is see 4.7 Timing Out setting.

(1) Gate mode set



When you change Timing ready to # by **CHG** key, signal output "High" level between Gate Start position and Gate Stop position.

Mark # in motor access screen is standby state to pulse out.

It's useful to change Gate Start position and Gate Stop position.

This function is always available for preset start and stop position.

If you don't need this output, change mark # to (sp). (sp) means "space" by **CHG** key.

(2) Pulse mode set

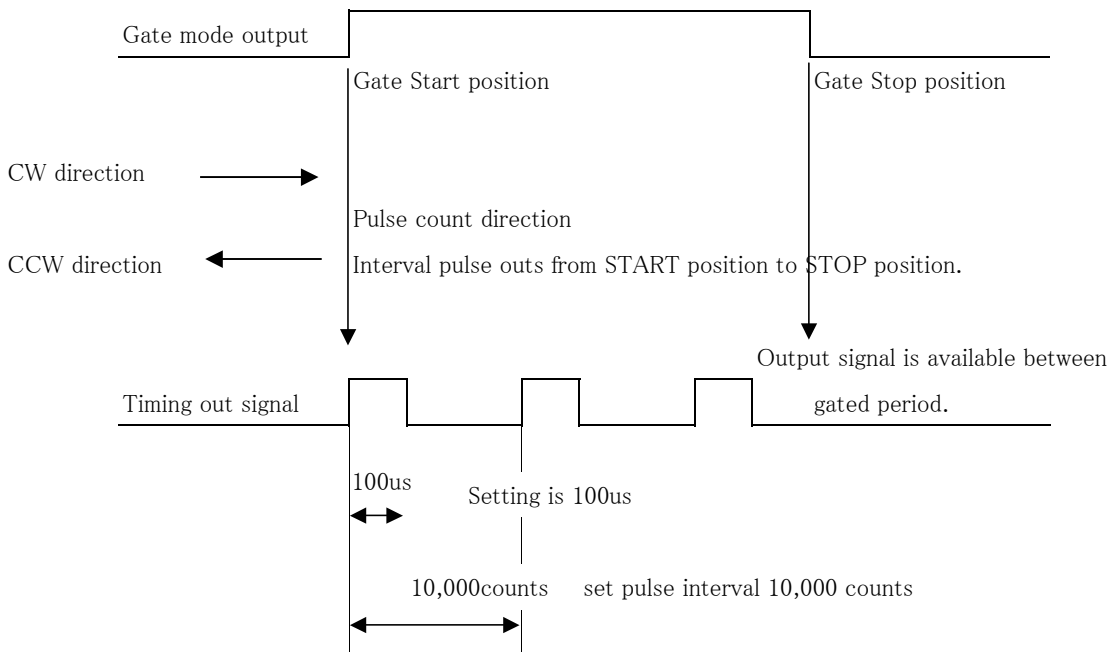

In pulse mode signal out only once to pulse direction.

To get this signal, it's need to set ready mark "#" by **CHG** key.

To get this signal continuously, it's need to set read before start position each time.

To get this signal to CCW direction move, it's need to set "Gate stop position" < "Gate Start position".

And initial position must be bigger than "Gate Start position" then timing out ready and start motor.

(In addition)

When in timing out mode, pulse position goes "Gate Start position" mark # turns (sp).

When motor stopped between gated area, and back to start position, then start from "Gate start position", signal outs continuously.

Once motor go through "Gate Stop position", pulse out ability had finished then no output signal.

5.3 Hand box control (Optional)

•04TYPE Hand box controller (PM16-HDX 4 axis control)

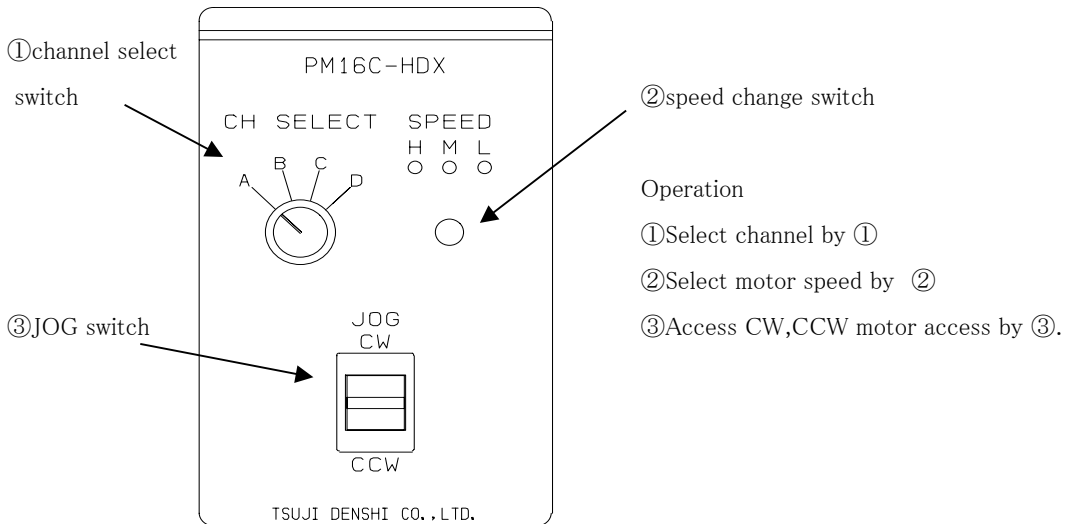

This controller is useful in local mode.

You can control A,B,C,D channels far from 3m of PM16C.

Preset speed is indicated by LED display.

•02TYPE Hand box controller (PM16-HDX 2 axis simultaneous control)

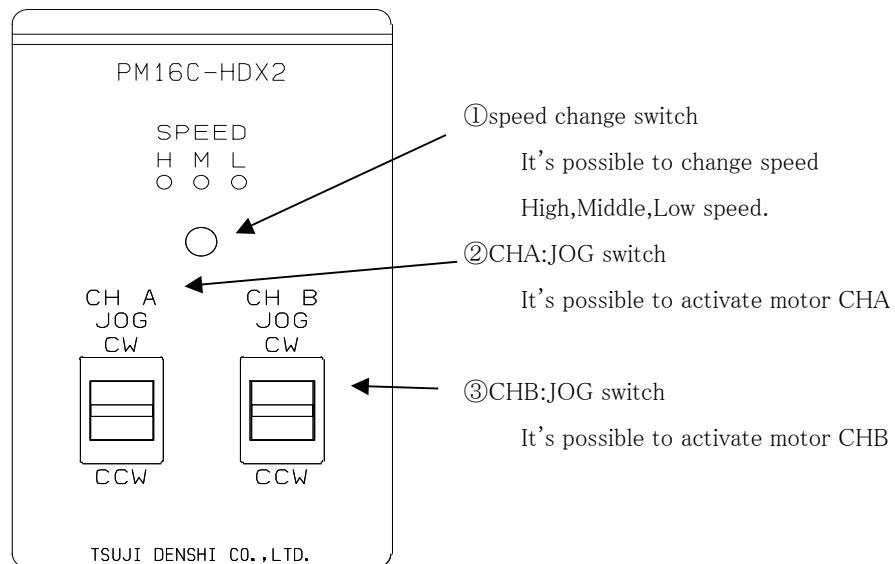

Incase of Type 02, 2 motors are activate simoultainiously.

•16TYPE Hand box controller(PM16-HDX16 16 axis selected control)

0 to 15(F) channel control can be selected.

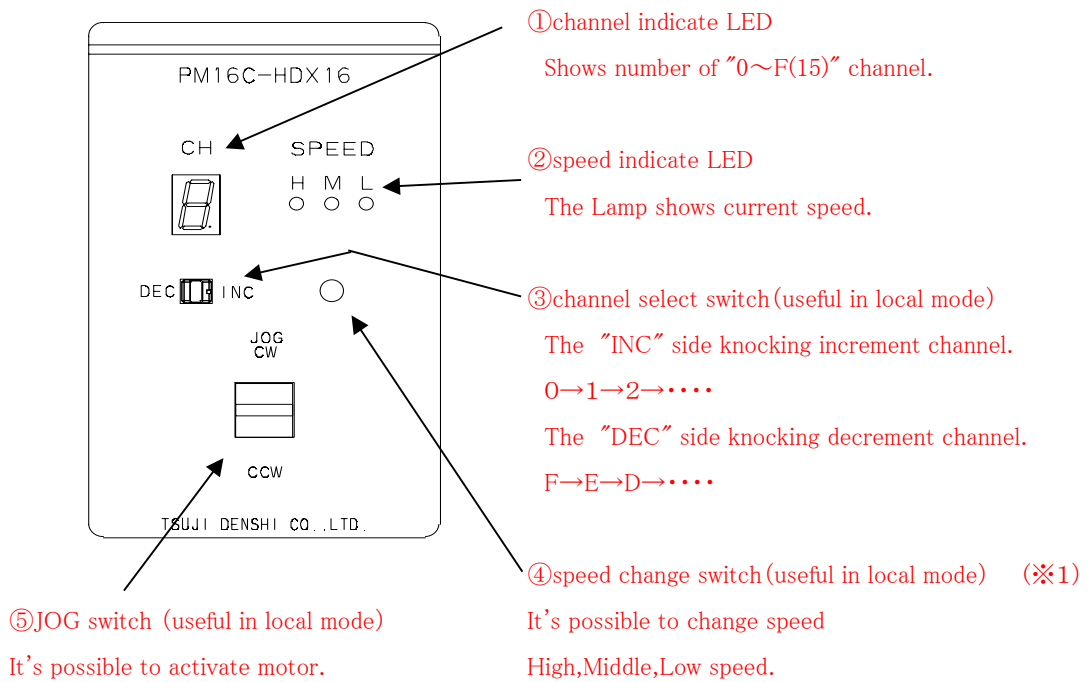

(※1) By over three second pressing of this button when it is remote, "H, M, and L" of the speed indicator lamp light, and then the speed change button will work as a motor STOP button. It is convenient to stop the motor at a place away from the unit by the Hand box. To change this mode to normal over three second pressing of this button.

5. 4 Setting the origin of home position

Sometimes to control pulse motor controller, It's need to set home position.

This unit has H.P mode. By this mode it's easy to get home position of mechanical origin point.

Once H.P had got into unit, these related data are memorized.

(1) At the beginning

To get H.P data it's convenient to use origin sensor and origin limit switch.

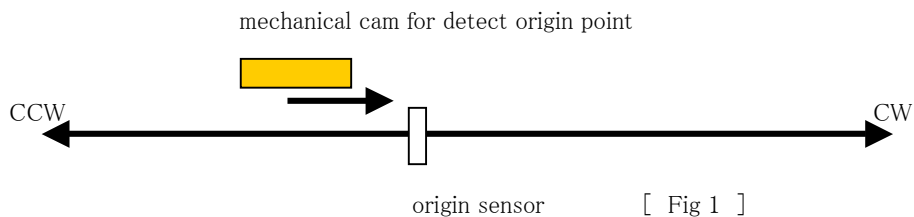

To set H.P, it's need to decide the direction of detecting origin point.

In this case, detect way is CW.

Once detect the origin point, motor stopped automatically and momorize the direction and H.P pulse data. In this case, motor speed must be low within response time of sensor.

It's need to check the set speed.

(2) Selection of detecting ways

There are three ways of detecting origin point.

Some are in case of memorized data had existed and another is incase of no memorized data.

WAY	ORIGINAL STATE	DETECT WAY	PROCEDURES	ACCURACY	TIME
A	NO MEMORIZED DATA	BY MANYUAL	Manyuaru operation JOG CW,CCW OR START +JOG CW,CCW	△	SHORT
B		SEMI AUTOMATICAL	By "START" switch ON more than 1 sec	◎	LONG
C	EXISTED MEMORIZED DATA	SEMI AUTOMATICAL	By "START" switch ON	◎	SHORT

[WAY A]

1. Set target channel to active.

See fig1. When you set H.P to direction CW, you have to set motor position to CCW side against origin sensor, then move motor from CCW to CW side by operation switch JOG CW or START + JOG CW.

2. Once detect the origin point, motor stopped suddenly, origin point procedures finished.

Then the position of pulse data is memorized and displyed LCD screen.

And direction of it CW had memorized in ORG.MEM 4.6 SETUP screen H.P set.

[WAY B]

1. Set target channel to active.

See fig2. When you set H.P to direction CW, you have to set start direction to CCW.

In this case ORG. START (4. 4 P4 :Acceleration and deceleration setting) must be CCW.

Then push START button more than 1 sec, it starts H.P action.

(a). In case of start position is in CW side against origin point

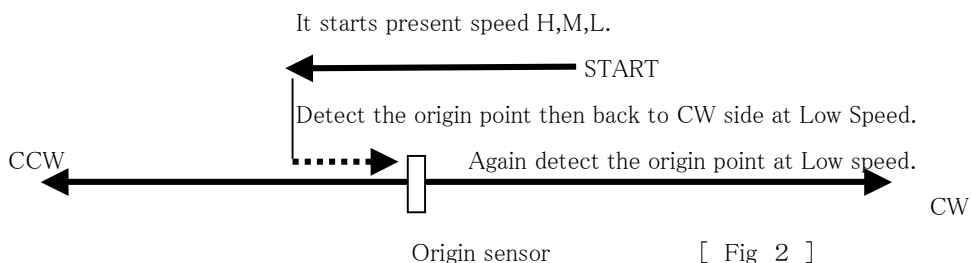

[Fig 2]

(b). In case of start position is in CCW side against origin point

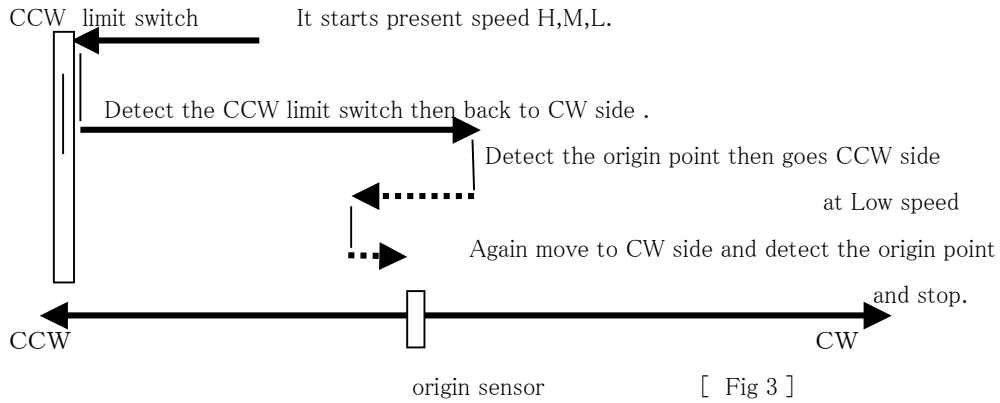

2. Once detect the origin point, motor stopped suddenly, origin point procedures has finished.

Then the position of pulse data is memorized and displayed LCD screen.

And direction of it CW had memorized in ORG.MEM 4.4 SETUP screen H.P set.

While in this procedures, if you stop this operation by "STOP" switch, H.P hadn't been finished.

If in this procedures, CW or CCW limit switch or digital limit switch is activate, detecting procedures continue until STOP button on.

[WAY C]

1. Set target channel to active.

In this case this set is resetting of H.P set.

According to related data, this mode is done in high accuracy and in short time automatically.

2. If you push START button, motor goes to origin direction by preset speed

to origin point \pm Offset Pulse area. Offset pulse is set by 4.4 SETUP screen H.P set.

Default value of it is 100.

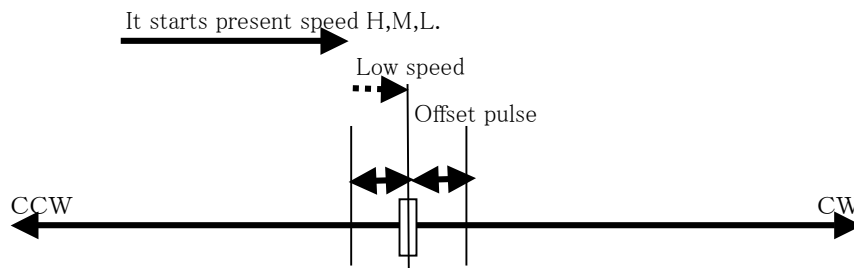

[Fig 4]

3. When motor enter the offset area, then goes to origin point at Low speed then detect the origin point and stopped motor. Thus H.P procedures has finished.

While in this procedures, CW, CCW limit switch activate or push STOP button,

This procedures stopped, H.P state is " NO. H.P".

But even in this state, you set CHG key in MEM.POS (4.4 SETUP screen H.P set)

you can bring back past data to display and set.

6. Rear panel

6. 1 Appearance of rear panel is as follows

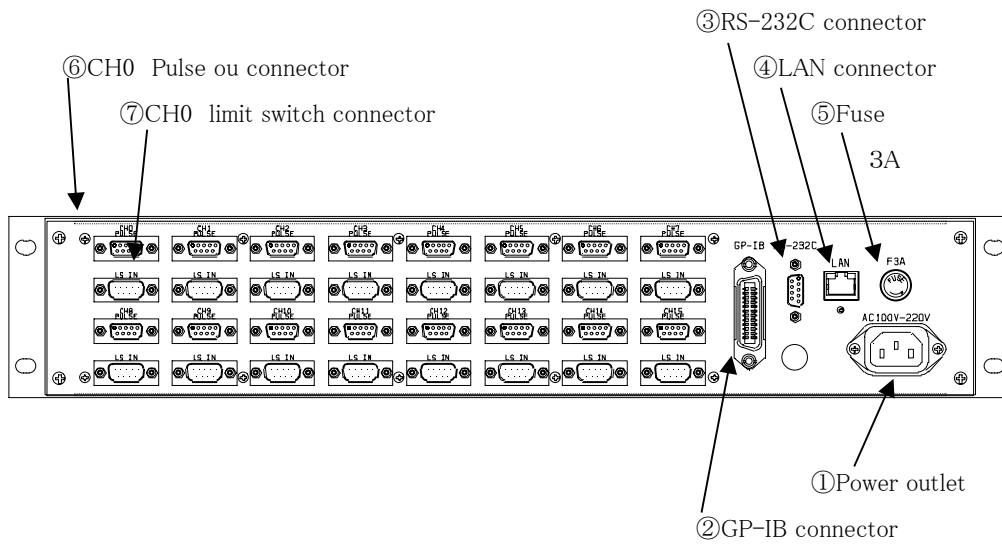

Connectors of CH0~CH15 are located in order.

6. 2 Connection of external devices

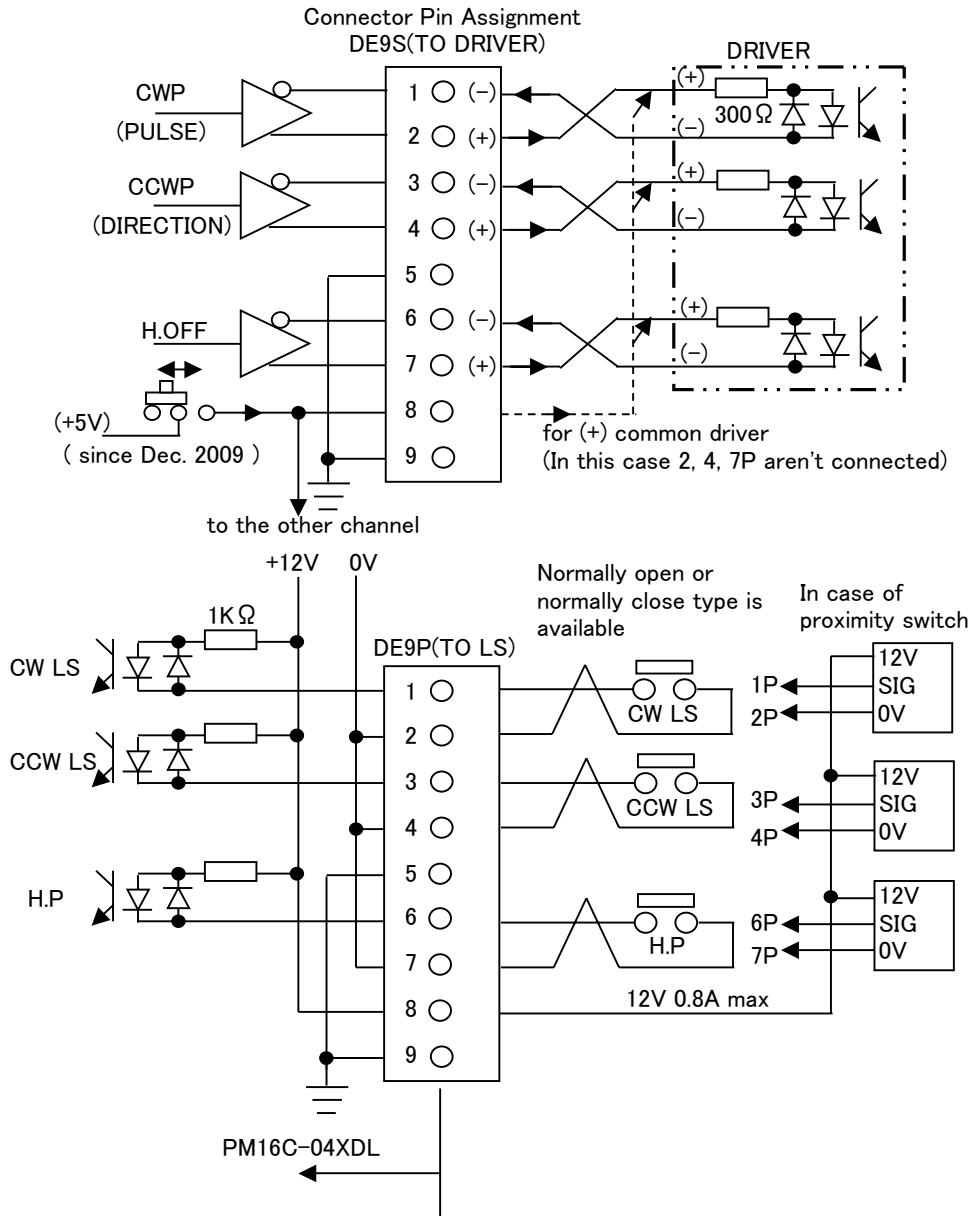

(NOTE)

- Shell size of connector is different from manufactures.
- Select the outside dimension of width of connector is under 35 mm.
- Our recommend one is DE-C1-J6(JAE), XM2S-0911(OMRON), HDE-CTF(HIROSE).

7. Acceleration and Deceleration Rate

Acceleration and Deceleration Rate are given by code number 0 ~ 115 those mean actual rate data below.

Rate Data Table (unit: ms/1000pps)

NO	RATE	NO	RATE	NO	RATE	NO	RATE	NO	RATE	NO	RATE
0	1000	20	150	40	22	60	3.3	80	0.47	100	####
1	910	21	130	41	20	61	3.0	81	0.43	101	####
2	820	22	120	42	18	62	2.7	82	0.39	102	####
3	750	23	110	43	16	63	2.4	83	0.36	103	####
4	680	24	100	44	15	64	2.2	84	0.33	104	####
5	620	25	91	45	13	65	2.0	85	0.30	105	####
6	560	26	82	46	12	66	1.8	86	0.27	106	####
7	510	27	75	47	11	67	1.6	87	0.24	107	####
8	470	28	68	48	10	68	1.5	88	0.22	108	####
9	430	29	62	49	9.1	69	1.3	89	0.20	109	####
10	390	30	56	50	8.2	70	1.2	90	0.18	110	####
11	360	31	51	51	7.5	71	1.1	91	0.16	111	####
12	330	32	47	52	6.8	72	1.0	92	0.15	112	####
13	300	33	43	53	6.2	73	0.91	93	0.13	113	####
14	270	34	39	54	5.6	74	0.82	94	0.12	114	####
15	240	35	36	55	5.1	75	0.75	95	0.11	115	####
16	220	36	33	56	4.7	76	0.68	96	0.10		
17	200	37	30	57	4.3	77	0.62	97	0.09		
18	180	38	27	58	3.9	78	0.56	98	0.08		
19	160	39	24	59	3.6	79	0.51	99	0.08		

8. Performance and specifications

Term	ITEM	REMARKS
Power	Voltage and frequency	AC 85 ~ 264V, 47 ~ 440Hz, 50VA
IN/OUT	Control motor Capability Out put Pulse rate Pulse control number Acceleration and deceleration rate Acceleration and deceleration form Output format Pulse out connector Limit switch input Limit switch connector	16 motors can be controlled 4 motors can be controlled synchronously or simultaneously CW, CCW, HOLE OFF (5V, 8mA: line driven) for each 16 motor driver 1~5MPPS 0~±2,147,483,647 1048.56~0.0125 ms/KHz Constant speed, S-character form, trapezoidal form 2 pulse / 1pulse and 1 direction DE9S(F)/PM16C-05XDL, RJ-4/PM-16C04XR CW-LS, CCW-LS, HOME-LS 12V 5mA (minus common) and power supply +12v for censer for each motor (total 1A). DE9S(M)/PM16C-05XDL, RJ-4/PM-16C04XR
LCD display	Characters and lines of display device Display contents in active mode Display contents in data set mode	PM16C-04XDL: 20characters × 4 lines (Size : 9.2H × 4.8W) channel number, current position of ±10 digit number, speed display, contents of limit switch, relative moving value, preset count value, home position information, panel operation ready/not ready limit switch setting information, pulse output mode, value of speed HSPD/MSPD/LSPD, acceleration and deceleration rate value, Push button stop mode, origin detect function, timing pulse generate function, RS232C settings, GP-IB settings, HAND BOX selection, FIRMWARE version selection
Panel push button and lamp	PM16C-04XDL	switch and button: CH-SEL, JOG CW/CCW, channel act, REM/LOC, SETUP, PRESET, START, STOP, CURSOR, CHG, MODE, ten-key lamp: limit switch, home position, hold off, motor select, PRESET, START, STOP, REM/LOC, SETUP, MODE
Ten-key and cursor key		channel selection by ten-key and cursor key. Selection of control ready/not ready for each channel, and change preset values. selectable speed of H, M, L for each channel. and preset speed value of H,M,L for each channel.
Control	PRESET START STOP JOG	preset specified data to the selected display moving start for selected channel according to the mode stop moving for selected channel jog stepping for selected channel
Stepping mode	SCAN MODE ABS IDX MODE REL IDX MODE HP STOP MODE	continuous stepping operation of ready channel. Stepping direction is according JOG switch. moving to specified position of ready channel moving specified steps of ready channel stop by Home Position Limit Switch total 3 moving style. 1 is for with HP detection memory, another is for no HP detection memory.

Term	ITEM	REMARKS
Remote control	communication way	LAN, GP-IB, RS232C port
Case	size and weight	EIA 2 UNIT rack mount type (88H×482W×325D) 4.5Kg

For the further information, feel free to ask us.

Tsuji-Electronics Co., Ltd

TEL: +81-(0)29-832-3031 FAX: +81-(0)29-832-2662

E-mail : info2@tsuji-denshi.co.jp

URL : <http://www.tsujicon.jp>

3739, Kandatsu-machi, Tsuchiura-city, Ibaraki 300-0013, Japan