

Synchronized
2ch NIM V/F CONVERTER
SN2VF-01

(2376 Ver. 2)

SER No. _____



TSUJICON

APPLICATION OF ELECTRONIC DEVICES

TSUJI ELECTRONICS CO., LTD

3739 Kandatsu-machi Tsuchiura-city
Ibaraki-Pref 300-0013 Japan

Phone +81-(0)29-832-3031
fax +81-(0)29-832-2662

URL <http://www.tsujicon.jp>
E-mail info2@tsuji-denshi.co.jp

NIM V-F CONVERTER USER'S MANUAL

Type SN2VF-01

A X'tal synchronized ¹⁾ V-F Converter constructed in a NIM-1 UNIT case has two channels outputs and include a four stage amplification factor switch and a polarity selector switch. In addition, with over range and polarity displayed, V-F conversion is always performed at the optimum conditions. The over range signal is output as a transistor open-collector signal which can be used as a warning. The DC amplifier can be used under isolated (floated) condition from the NIM power source, providing higher noise tolerance. Analog output that is the signal just before V/F conversion can be used as an amplified signal monitor.

1. Specification

- | | |
|------------------------|---|
| 1) Gain | 1MHz/10V, 1MHz/1V, 1MHz/100mV, 1MHz/10mV |
| 2) Input Voltage | 0 ~ 10V (Acceptable input $\pm 100V$ Max) |
| 3) Input Resistance | 1M Ω |
| 4) Output | TTL level positive logic 0 ~ 1MHz |
| 5) Conversion Accuracy | $< \pm 0.02\%$ /FS |
| 6) Power Supply | +12V about 600mA (From NIM Connector) |
| 7) Case | NIM-1 |

2. Panel lay out

1) Front panel layout

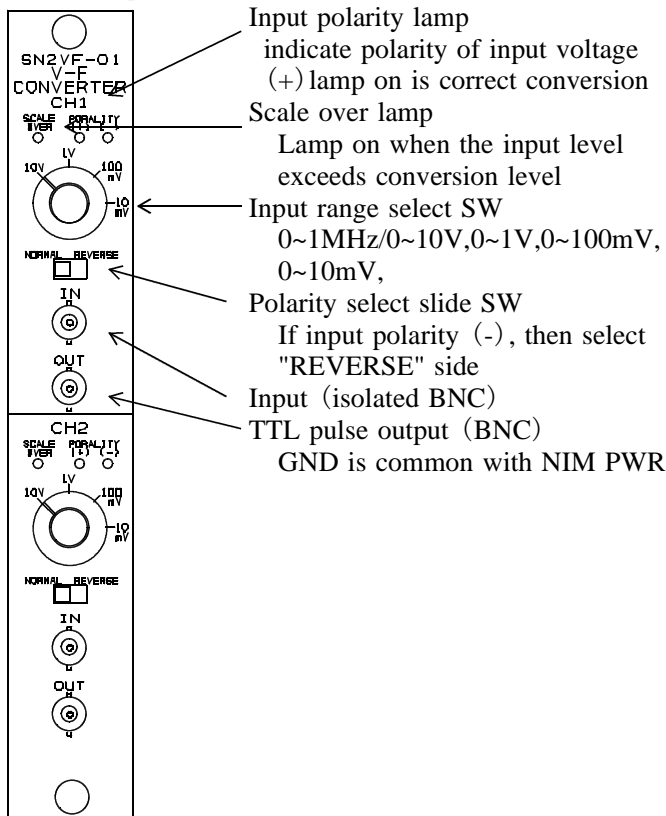

2) Rear panel layout

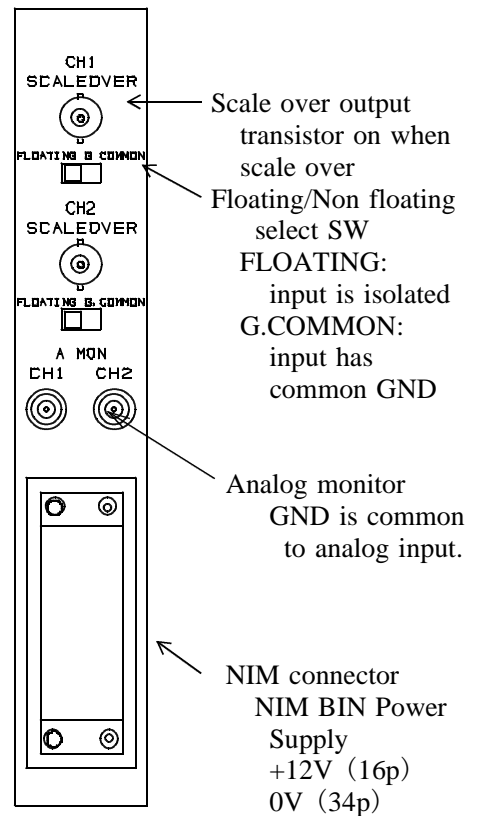

3. Circuit of input/output

1) Voltage input

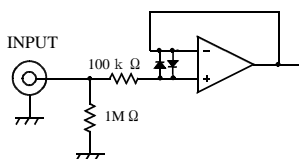

2) Pulse out

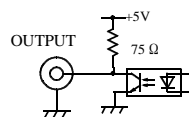

3) Scale over out

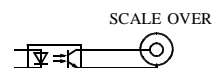

¹⁾ About X'tal synchronized V/F converter

Using the stability of X'tal enables low cost performance of V/F conversion.

Output frequency may be the mixture of some periods of pulse signals because of digital processing.