

8CH Counter / Timer with 2CH Encoder Counter  
CT08-ER2T, CT16-ER2T  
USER'S MANUAL

4391 (Rev5)



TSUJICON

APPLICATION OF ELECTRONIC DEVICES

**TSUJI ELECTRONICS CO.,LTD**

3739 Kandatsu-machi Tsuchiura-city  
Ibaraki-Pre 300-0013 Japan  
Phone +81-(0)29-832-3031  
Fax +81-(0)29-832-2662  
URL <https://www.tsujicon.jp>  
E-mail [info2@tsuji-denshi.co.jp](mailto:info2@tsuji-denshi.co.jp)

COMMAND	FUNCTION	DETAIL
ALM?	alarm read 0-15ch	read out the cause of overflow 0-15CH and timer Reply: overXXXXTM or overXXXX--
ALMX?	alarm read extended to 0-xxch xx: 07 to 15	read out the cause of overflow 0-xxCH and timer Reply: overXXXXXXXXTM or overXXXXXXXX--
CLAL	clear all	clear timer and all channel counters
CLPC	clear preset counter	clear preset counter (CH7)
CLTM	clear timer	clear timer
CLCTxx	clear counter xx	clear counter channel xx xx:00-15
CLCTxxyy	clear counter xx to yy	clear counter channel xx to yy xx, yy:00-15
CPR?	counter preset data read	read out preset counter data Reply: 8 digits in dec (Kcts unit) (ex:00010000)
CPRF?	counter preset data read	read out preset counter data Reply: 8 digits in dec (cts unit) (ex:00010000)
CTMR?uuvvww	counter uu to vv and timer read	read out from channel uu to vv counter and timer uu, vv:00-17 Reply: 10 digits in dec ww: 00/no timer, 01/timer
CTMRH?uuvvww	counter uu to vv and timer read	read out from channel uu to vv counter and timer uu, vv:00-17 Reply: 8 digits in hex ww: 00/no timer, 01/timer
CTR?xx	counter xx read	read out channel xx counter xx:00-17 Reply: 10 digits in dec
CTRH?xx	counter xx read	read out channel xx counter xx:00-17 Reply: 8 digits in hex
CTR?xxyy	counter xx to yy read	read out channel xx counter xx, yy:00-17 Reply: 10 digits in dec (separated by space)
CTRH?xxyy	counter xx to yy read	read out from channel xx to yy counter xx, yy:00-17 Reply: 8 digits in hex (separated by space)
DSAS	disable auto stop	disable automatic stop until using STOP command
ENCS	enable counter stop	enable counter stop
ENTS	enable timer stop	enable timer stop
GATEIN_DS	gate in disable	gate in disable (counting, even if gate in)
GATEIN_EN	gate in enable	gate in enable (default)
GATEIN?	ask gate in mode	ask gate in mode reply : EN or DS
MOD?	mode read	read out counter mode
RDAL?	read all counter and timer	read out all counter and timer/Reply: 10 digits in dec
RDALH?	read all counter and timer	read out all counter and timer/Reply: 8 digits in hex
SCPRdddd.....	set counter preset data	set preset data to counter (Kcts unit)
SCPRFdddd.....	set counter preset data	set preset data to counter (cts unit)
TPR?	timer preset data read	read out preset timer data (ms unit)
TPRF?	timer preset data read	read out preset timer data ( $\mu$ s unit)
STOP	stop counter	deactivate counting action
STPRdddd.....	set preset counter to dddd.....	set preset timer value (ms unit)
STPRFdddd.....	set preset counter to dddd.....	set preset timer value ( $\mu$ s unit)
STRT	start counter	start counting action
TMR?	timer read	read out timer value Reply: 10 digits in dec
TMRH?	timer read	read out timer value Reply: 10 digits in hex
VER?	version information read	read out software version information Reply: "1.00 11-11-11 CT08-ER2T" (example)
VERH?	hardware version information	read out hardware version information Reply: "HD-VER 1" (example)
REST	reset and start	set the unit restart (It's same as power on sequence)
FLG?x (x:0, 1, 2, 3)	read internal flag	read out internal state flag inside

Store data commands for synchronous gate signal and timer clock

URL <https://www.tsujicon.jp>

COMMAND	FUNCTION	DETAIL
CLGSDN	Clear Gate Synchronous Data Number	clear current data acquisition address (set data address to zero)
CLGSAL	Clear Gate Synchronous acquired All data	clear current data address and all memory data (It takes 30 seconds in all data clear)
GSDNddd...	Gate Synchronous Data acquisition data Number set to	input gate synchronous data acquisition data address
GSDN?	Gate Synchronous Data acquisition data Number read	read out gate synchronous data acquisition data address Reply : 0 ~ 9999
GSEDddd...	Gate Synchronous acquisition End data Number set to	input gate synchronous data acquisition end data address. (after end address, acquisition stop.)
GSED?	Gate Synchronous acquisition End data Number read	read gate synchronous data end address Reply : 0 ~ 9999
GT_ACQ_DIF	GateSync. Differential Data Acq.	Differential data acquisition mode
GT_ACQ_FUL	GateSync. Full Data Acq.	Full data acquisition mode (default)
GT_ACQ?	Ask Diff or Full	Ask acquisition mode reply : FUL or DIF

Synchronous GATE signal data acquisition commands

COMMAND	FUNCTION	DETAIL
GSTRT	Gate synchronous data acquisition STaRT	start gate synchronous data acquisition (just after turn on power, it's stop condition)
GESTRT	Gate Edge synchronous data acquisition STaRT	start gate edge synchronous data acquisition (just after turn on power, it's stop condition)

Synchronous internal clock data acquisition commands

COMMAND	FUNCTION	DETAIL
GTRUNddd...	Gate Timer synchronous RUN time	input synchronous timer data RUN time ( $\mu$ s units)
GTRUN?	Gate Timer synchronous RUN time read	read out synchronous timer data RUN time
GTOFFddd...	Gate Timer synchronous OFF time	input synchronous timer data OFF time ( $\mu$ s units. 120ns as minimum, when the off time is zero.)
GTOFF?	Gate Timer synchronous OFF time read	read out synchronous timer data OFF time
GTSTRT	Gate Timer synchronous data acquisition STaRT	start internal clock synchronous data acquisition (Just after turn on power, it's stop condition)

## Synchronous data acquisition common commands

COMMAND	FUNCTION	DETAIL
STOP	gate synchronous data acquisition STOP	stop gate synchronous data acquisition (Same as command "STOP" of a counting stop )
GSTS?	Gate synchronous data acquisition Status read	read out the status of gate synchronous data acquisition
GSDAL?	Gate synchronous acquired all data(0-7ch & time) read	read out all gate synchronous data (0 ~ the present data number - 1) Reply: dec
GSDALX?	Gate synchronous acquired all data(0-xxch & time) read	read out all gate synchronous data (0 ~ the present data number - 1) Reply: dec
GSDALH?	Gate synchronous acquired all data(0-7ch & time) read	read out all gate synchronous data (0 ~ the present data number - 1) Reply: hex
GSDALXH?	Gate synchronous acquired all data(0-xxch & time) read	read out all gate synchronous data (0 ~ the present data number - 1) Reply: hex
GSDRD?xxxxyyyy	Gate synchronous acquired data (0-7ch) read from xxxx to yyyy	read gate synchronous data from xxxx to yyyy Reply: dec
GSDRD?xxxxyyyy(K)	Gate synchronous acquired data all ch read from xxxx to yyyy	read gate synchronous data from xxxx to yyyy data number is x1000, if (K) is added to command. Reply: dec
GSDRDH?xxxxyyyy	Gate synchronous acquired data (0-7ch) read from xxxx to yyyy	read gate synchronous data from xxxx to yyyy Reply: hex
GSDRDH?xxxxyyyy(K)	Gate synchronous acquired data all ch read from xxxx to yyyy	read gate synchronous data from xxxx to yyyy (Available LAN Hi-speed read mode) Reply: hex
GSCRD?uvwxxyyyyy	Gate synchronous acq. data read (u - v ch) from xxxx to yyyy	read gate synchronous data from xxxx to yyyy Reply: dec ch u to v, w:l with timer
GSCRD?uvwxxyyyyy(K)	Gate synchronous acq. data read (uu-vv ch)from xxxx to yyyy	read gate synchronous data from xxxx to yyyy Reply: dec ch uu to vv, ww: 01 with timer
GSCRDH?uvwxxyyyyy	Gate synchronous acq. data read (u - v ch) from xxxx to yyyy	read gate synchronous data from xxxx to yyyy Reply: hex ch u to v, w:l with timer
GSCRDH?uvwxxyyyyy(K)	Gate synchronous acq. data read (uu-vv ch)from xxxx to yyyy	read gate synchronous data from xxxx to yyyy Reply: hex ch uu to vv, ww: 01 with timer

## Synchronous internal clock data acquisition commands

COMMAND	FUNCTION	DETAIL
GTRUNddd...	Gate Timer synchronous RUN time	input synchronous timer data RUN time ( $\mu s$ units)
GTRUN?	Gate Timer synchronous RUN time read	read out synchronous timer data RUN time
GTOFFddd...	Gate Timer synchronous OFF time	input synchronous timer data OFF time ( $\mu s$ units. 120ns as minimum, when the off time is zero.)
GTOFF?	Gate Timer synchronous OFF time read	read out synchronous timer data OFF time

## Synchronous data acquisition common commands

COMMAND	FUNCTION	DETAIL
STOP	gate synchronous data acquisition STOP	stop gate synchronous data acquisition
GSTS?	Gate synchronous data acquisition Status read	read out the status of gate synchronous data acquisition

## Continuation synchronous reading command of a counter timer

COMMAND	FUNCTION	DETAIL
TSDL(H)uvw	Timer Synchronous DownLoad ch u to v and timer	Specify the counter ch from u to v and w/ or w/o timer data to download in synchronization with timer w: 0/no timer data, 1/timer data Reply: dec w/o "H", hex w/ "H"
TSDLX(H)uuvvww	Timer Synchronous DownLoad ch uu to vv and timer	Specify the counter ch from uu to vv and w/ or w/o timer data to download in synchronization with timer ww: 00/no timer data, 01/timer data Reply: dec w/o "H", hex w/ "H"
TSDL?	Timer Synchronous DownLoad Setting Read	Read out the counter ch and w/ or w/o timer data to download in synchronization with timer Reply (example) : H_uu_vv_ww, D_uu_vv_ww "H":hex "D":dec
TSDTxxx	Timer Synchronous DownLoad interval Time	Set interval time of download per ms.
TSDT?	interval Time read	interval Time read
TSDSTRT	Download START	Download START
TSDSTOP	Download STOP	Download STOP
XSDL(H)uvw	eXternal Synchronous DownLoad ch u to v and timer	Specify the counter ch from u to v and w/ or w/o timer data to download in sync with external gate signal w: 0/no timer data, 1/timer data Reply: dec w/o "H", hex w/ "H"
XSDLX(H)uuvvww	eXternal Synchronous DownLoad ch uu to vv and timer	Specify the counter ch from uu to vv and w/ or w/o timer data to download in sync with external gate signal ww: 00/no timer data, 01/timer data Reply: dec w/o "H", hex w/ "H"
XSDL?	eXternal Synchronous DownLoad Setting Read	Read out the counter ch and w/ or w/o timer data to download in sync with external gate signal Reply (example) : H_uu_vv_ww, D_uu_vv_ww "H":hex "D":dec
XSDSTRT	Download START	Download START
XSDSTOP	Download STOP	Download STOP
STOP	stop counter and Download	stop counter and Download

## LCD display function command (for a type with a display)

COMMAND	FUNCTION	DETAIL
SDUxx	set display upper row xx channel	set xx channel to LCD display upper row xx:00-07
SDUTM	set display upper row timer data	set timer data to LCD display upper row
SDUCP	set display upper row counter preset data	set counter preset data to LCD display upper row
SDUTP	set display upper row timer preset data	set timer preset data to LCD display upper row
SDLxx	set display lower row xx channel	set xx channel to LCD display lower row xx:00-07
SDLTM	set display lower row timer data	set timer to LCD display lower row
SDLCP	set display lower row counter preset data	set counter preset data to LCD display lower row
SDLTP	set display lower row timer preset data	set timer preset data to LCD display lower row
BKON	Back Light ON	Turn on back light
BKOFF	Back Light OFF	Turn off back light

LAN command

COMMAND	FUNCTION	DETAIL
MAC?	MAC address read Read only	reply (example) : 0050C2970018
IPAx <sub>xxx</sub> _x <sub>xxx</sub> _x <sub>xxx</sub> _x <sub>xxx</sub>	IP address set xxx: 000~255	Set IP address Activated after power on again or command "RSET"
IPA?	IP address read	Read IP address Reply (example) : IPA192_168_001_155
PRTx <sub>...</sub> x	Set port number example: PRT7777	Set port number Activated after power on again or command "RSET"
PRT?	Port number read	Read port number Reply (example) : PRT 7777
GTW <sub>xxx</sub> _x <sub>xxx</sub> _x <sub>xxx</sub> _x <sub>xxx</sub>	GateWay address set xxx: 000~255	Set LAN Gate Way address Activated after power on again or command "RSET"
GTW?	GateWay address read	Read LAN Gate Way address Reply (example) : GTW192_168_001_001
SNM <sub>xxx</sub> _x <sub>xxx</sub> _x <sub>xxx</sub> _x <sub>xxx</sub>	SubNetMask set xxx: 000~255	Set LAN Sub Net Mask Activated after power on again or command "RSET"
SNM?	SubNetMask read	Read LAN Sub Net Mask Reply (example) : SNM255_255_255_000

Special command (internal ROM initialize command. Please use it by USB communication, when IP address became unknown, or, when a problem occurred and should be initialized.)

COMMAND	FUNCTION	DETAIL
INITROM	Internal ROM data Initialize	Initialize internal ROM data Please see the section 4-5-6 for detail of initialize.

Command return "O.K" or "NG", when a command is not required to response

COMMAND	FUNCTION	DETAIL
ALL_REP_EN	All reply enable	Sets a reply for all the commands Reply "OK" or "NG" from the command except inquiry command
ALL_REP_DS	All reply disable	No reply from the commands except inquiry command
ALL_REP?	All reply mode request	Ask the status of "all reply enable" Reply: EN=enable, DS=disable

Command to set 10  $\mu$  s to minimum pulse width of RUN output (TTL)

COMMAND	FUNCTION	DETAIL
MIN10U_EN	Minimum 10u enable	Sets 10us to minimum pulse width
MIN10U_DS	Minimum 10u disable	Sets minimum pulse width as a condition
MIN10U?	MIN10U mode request	Ask MIN10U mode Reply: EN=mode on, DS=mode off

Input mode command

IN? xx	Return input mode settings of xx~xx+7 xx: 00, 08, 16, 24, 32, 40, 48, 56	Read input mode settings Reply: (xx=00) CH 00 - 07 : TTL_Hi TTL_Hi TTL_50 TTL_50 NIM NIM TTL_50 TTL_50 (xx=56) CH 56 - 63 : TTL_Hi TTL_Hi TTL_50 TTL_50 NIM NIM TTL_50 TTL_50
THI ALL	Sets all channel to TTL Hi-Z	Set the input mode of all channels to TTL Hi-Z Reply: OK
THI x	Sets CHx and CHx+1 to TTL Hi-Z x: 0, 2, 4, ..... , 62	Set the input mode of CHx amd CHx+1 to TTL Hi-Z Reply: OK
T50 ALL	Sets all channel to TTL 50 Ω	Set all channel input mode to TTL 50 Ω Reply: OK
T50 x	Sets CHx and CHx+1 to TTL 50 Ω x: 0, 2, 4, ..... , 62	Set the input mode of CHx amd CHx+1 to TTL 50 Ω Reply: OK
NIM ALL	Sets all channel to NIM	Set all channel input mode to NIM Reply: OK
NIM x	Sets CHx and CHx+1 to NIM x: 0, 2, 4, ..... , 62	Set the input mode of CHx amd CHx+1 to NIM Reply: OK

External Control Signal Polarity Selection Command (Hardware Version 5 or later)

PGATE?	Inquires GATE Signal Polarity	Returns GATE signal polarity Response: Positive or Negative
PGATEP	Sets GATE polarity to positive	Sets GATE polarity to positive Reply: OK
PGATEN	Sets GATE polarity to negative	Sets GATE polarity to negative Reply: OK
PSTART?	Inquires Start Signal Polarity	Returns START signal polarity Response: Positive or Negative
PSTARTP	Sets START polarity to positive	Sets START polarity to positive Reply: OK
PSTARTN	Sets START polarity to negative	Sets START polarity to negative Reply: OK
PSTOP?	Inquires STOP Signal Polarity	Returns STOP signal polarity Response: Positive or Negative
PSTOPP	Sets STOP polarity to positive	Sets STOP polarity to positive Reply: OK
PSTOPN	Sets STOP polarity to negative	Sets STOP polarity to negative Reply: OK
PRUN?	Inquires RUN Signal Polarity	Returns RUN signal polarity Response: Positive or Negative
PRUNP	Sets RUN polarity to positive	Sets RUN polarity to positive Reply: OK
PRUNN	Sets RUN polarity to negative	Sets RUN polarity to negative Reply: OK

Command for Encoder Counter

COMMAND	FUNCTION	DETAIL
S30	Encoder chA read	chA counter read request Reply:RA±□□□□□□ (□:Decimal)
S32	Encoder chB read	chB counter read request Reply:RB±□□□□□□ (□:Decimal)
SA±□□□□□□	Encoder chA preset	chA counter preset (□:Decimal)
SB±□□□□□□	Encoder chA preset	chB counter preset (□:Decimal)
S20x	Encoder chA count mode set	Setting chA x: F/cw up, R/ccw up, 1/1times, 2/2times, 4/4times
S22x	Encoder chB count mode set	Setting chB x: F/cw up, R/ccw up, 1/1times, 2/2times, 4/4times
ZC□	counter clear by z-phase sig enable	Z-phase counter clear request □:A~B
ZN□	counter clear by z-phase sig disable	Z-phase counter clear cancel □:A~B
ZT□△	counter clear timing set	Select "Z-phase rising edge" or "Z-phase falling edge", to set the timing of clearing the counter. □:A~B, △:U/rise edge, D/fall edge
ZS□	counter clear setting read	Z-phase counter clear status read □:A~B
MW△±□□□□□□□□ (must be in the format)	Multiplier set	Scaling Parameter:multipier setting △:A~B, □:Decimal number
MR△	Multiplier read	Scaling Parameter:multipier read request reply:M△±□□□□□□□□
OW△±□□□□□□	Offset set	Scaling Parameter:offset setting △:A~B, □:Decimal number
OR△	Offset read	Scaling Parameter:offset read request reply:O△±□□□□□□□□□□ △:A~B, □:10digit
D△	Scaled value read	Scaled value read request reply:D△±□□□□□□□□□□ △:A~B, □:10digit

Command for Encoder Counter(2) Encoder synchronous trigger related

COMMAND	FUNCTION	DETAIL
EATE	Encoder A sync Trigger Enable	Enables counter operation for chA synchronous trigger output.
EATD	Encoder A sync Trigger Disable	Disables counter operation for chA synchronous output is disabled.
EAT?	Encoder A sync Trigger Enable/Disable status read	Reads the operation permission status of the counter for the synchronous trigger output on chA. Reply: Enable=EN, Disable=DS
EBTE	Encoder B sync Trigger Enable	Enables counter operation for chB synchronous trigger output.
EBTD	Encoder B sync Trigger Disable	Disables counter operation for chB synchronous output is disabled.
EBT?	Encoder B sync Trigger Enable/Disable status read	Reads the operation permission status of the counter for the synchronous trigger output on chB. Reply: Enable=EN, Disable=DS
EATC±□□□□□□	Encoder A sync Trigger Count set	Sets the number of output counts for chA synchronous trigger.
EATC?	Encoder A sync Trigger Count set value read	Reads the output count setting for the synchronous trigger of chA. Reply: EATC±□□□□□□ (□ is dec.)

EATCC?	Encoder A sync Trigger Count Current value read	Reads the current value of the counter for the synchronous trigger output of chA. Reply: EATCC ± □□□□ (□ is dec.)
EBTC ± □□□□	Encoder B sync Trigger Count set	Sets the number of output counts for chB synchronous trigger.
EBTC?	Encoder B sync Trigger Count set value read	Reads the output count setting for the synchronous trigger of chB. Reply: EBTC ± □□□□ (□ is dec.)
EBTCC?	Encoder B sync Trigger Count Current value read	Reads the current value of the counter for the synchronous trigger output of chB. Reply: EBTCC ± □□□□ (□ is dec.)
ENCTW □□□□	Encoder sync Trigger pulse width (μs) set	Sets the encoder synchronous trigger output pulse width. The setting range is 10 μs to 1ms, and the setting resolution is 10 μs.
ENCTW?	Encoder sync Trigger pulse width (μs) set value read	Reads the encoder synchronous trigger output pulse width setting. Reply: ENCTW □□□□
ENCTP □	Encoder sync Trigger polarity set	Sets the polarity of the encoder synchronous trigger output pulse. □=POS for positive logic, □=NEG for negative logic.
ENCTP?	Encoder sync Trigger polarity set value read	Reads the encoder synchronous trigger output pulse polarity setting. Reply: POS or NEG

## CONTENTS

1. Specifications .....	11
1-1. Abstract .....	11
1-2. Appearance .....	11
1-3. Block Diagram .....	13
2. Before using .....	14
2-1. Select input signal level for count and read input mode settings .....	14
2-2. Setting LAN communication .....	14
2-2-1. Preparation for setting .....	14
2-2-2. Change setting of network .....	15
2-2-3. Turn back PC set data .....	15
2-2-4. Connection test .....	15
2-3. Setting USB communication .....	16
2-3-1. Preparations for setting .....	16
2-3-2. Connecting test .....	16
2-4. Connect communication cables .....	16
2-4-1. Connect communication cables .....	16
2-4-2. Setting and reading the count input signal level .....	17
2-4-3. Connect count signal .....	17
2-4-4. Start signal (TTL positive logic) .....	17
2-4-5. Stop signal (TTL positive logic) .....	17
2-4-6. Gate signal (TTL positive logic) .....	18
2-4-7. Monitor out signal (In counting, TTL positive logic) .....	18
3. Communication commands .....	19
3-1. Communication commands .....	19
3-2. Read-out commands for counter set and the status of setting .....	19
3-2-1. Stop enable by count value .....	19
3-2-2. Stop enable by timer value .....	19
3-2-3. Stop disable by counter timer .....	19
3-2-4. Inquiry of action mode .....	19
3-2-5. Setting and readout of preset counter .....	19
3-2-6. Setting and readout of preset timer .....	20
3-3. Commands of counter operation .....	20
3-3-1. Counter start .....	20
3-3-2. Counter stop .....	20
3-3-3. Gate in enable/disable .....	20
3-4. Read-out and clear commands for counter and timer .....	21
3-4-1. Read-out and clear commands for all counter and timer .....	21
3-4-2. Read-out and clear commands for all counter .....	21
3-4-3. Read-out and clear commands for timer and setting reading .....	22
3-4-4. The continuation read of the synchronous timer counter by an internal timer .....	23
3-4-5. The continuation read of the synchronous timer counter by the external gate input .....	24
3-5. Inquiry of over-flow count data .....	26
3-6. Inquiry of software version information .....	26
3-7. Other commands .....	26
1) All reply mode : Command return "O. K" or "NG", when a command is not required to response .....	26
2) Command to read internal flag of counter .....	27
4. Counter data acquisition commands for internal RAM .....	28
4-1. About count data acquisition commands .....	28
4-2. Preparation for data acquisition commands .....	28
4-2-1. Clear current data address .....	29
4-2-2. Clear current data address and all stored data .....	29
4-2-3. Set and read gate synchronous data acquisition current data address .....	29
4-2-4. Set and read gate synchronous data acquisition end data address .....	29
4-2-5. Setting of an accumulated data acquisition and an increment data acquisition .....	29

4-3 Synchronous gate signal data acquisition commands .....	30
4-4 Synchronous internal clock data acquisition commands .....	30
4-4-1 Set and read synchronous timer RUN time .....	30
4-4-2 Set and read synchronous timer OFF time .....	30
4-4-3 Start synchronous timer clock data acquisition .....	31
4-5 Common commands on synchronous data acquisition .....	31
4-5-1.Counter stop .....	31
4-5-2.Read out the status of synchronous gate data acquisition .....	31
4-5-3.Read out all stored data(0~current data address) .....	31
4-5-4.Read out stored data of specific range .....	32
4-5-5.LAN set up commandsLAN set up commands .....	34
4-5-6.Special commands .....	35
4-5-7.Data read time .....	36
5.Encoder Counter .....	37
5-1.Read and Preset .....	37
5-1-1.Encoder Counter read command .....	37
5-1-2.Encoder Counter preset command .....	37
5-2.Encoder Counter setting .....	37
5-2-1.Direction of rotation and Count UP/DOWN .....	37
5-2-2.Setting confirmation command .....	38
5-3.Clarar Encoder Counter by Z-phase signal .....	38
5-4.Set scaling parameter .....	38
5-4-1.Multiplier setting command .....	38
5-4-2.Offset setting comand .....	39
5-4-3.Scaled value read command .....	39
5-5. Encoder Counter Synchronization Trigger Settings .....	40
6.Abstract of LCD display .....	42
6-1.Spec of LCD display .....	42
6-2.LCD display commands .....	42
6-3.Backlight control commands .....	42
6-4.Scaling function .....	42
7.Firmware update .....	43
8.Synchronous drive of multi units .....	44
9.Designation and cancellation of RUN output TTL pulse width $10\mu s$ at the minimum .....	44
10.Regulations and guidelines .....	44
11. Interface with external devices .....	45
12. Regarding to remote controlled input termination switch .....	45
13.Trial software .....	46
14.Performance and specifications .....	47

# User's manual

## 1. Specifications

### 1-1. Abstract

CT08 (16) -ER2T is based on the 8ch counter timer CT08-01D, it is a multifunction machine plus the function of 2ch encoder counter ER2C-04. Position information and counter information such as when continuously acquires the count data that depends on the position can be acquired simultaneously.

Set time until 0.000001 seconds to more than 1,000,000 seconds, set number of counts can be set to any until 1cts ~ 4,294,967Kcts. The case is EIA2. The 16-character × 2-stage LCD display of larger character size 8 × 5, from among timers and counters and encoder counter, two channels will be displayed. External communication is a LAN or USB.

In synchronization with the GATE IN signal ON / OFF or internal clock you can collect the data up to a maximum of 30,000. It can also be used as a counter-timer CT08 (16) -01D.

And it can also be used as an encoder counter ER2C-04.

If you want to collect data in accordance with the timing in timer synchronization and gate synchronization is a counter-timer function, will be collected at the same time as the counter data of the data also ch8, ch9 of encoder counter. In the case of the CT16, the data of the encoder counter will be collected at the same time as the counter data to ch16, ch17.

CT08(16)-ER2T now allows for data acquisition using encoder-synchronous triggering.

Encoder-synchronous trigger output terminal has also been added.

### 1-2. Appearance(CT08-ER2T)

#### Front panel layout

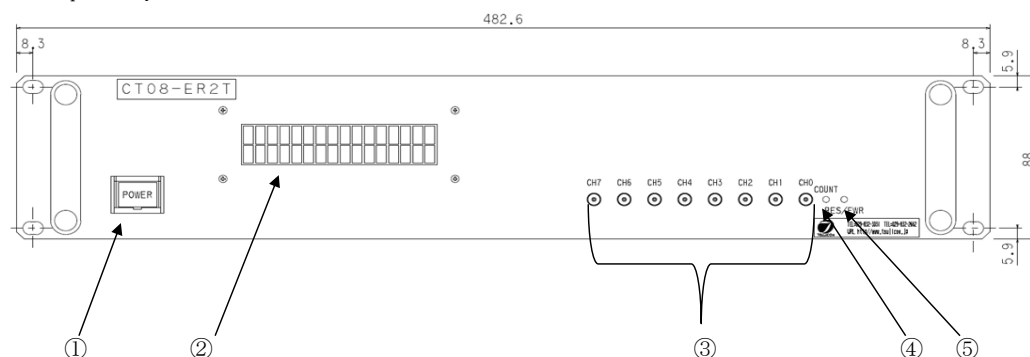

① Power switch The lamp of the switch is on when the power is on.

② LCD display (16 characters and Two lines)

It can display two items from the following 4 items into the two sections (upper row and lower row).

Count value, Timer value, Preset count value, Timer preset value

③ Input connectors for the Counters. There are CH0 to CH17. (INPUT)

It's possible to set preset value only for CH7.

④ It shows the beginning of count action. LED "ON" means the Counter gate open.

⑤ Reset button.

If the pushing is less than 1 second, the same reset action as power-up is executed

If the pushing is more than 3 seconds, the Counter moves to the firmware version up mode.

Please refer to the section "7.Firmware update" for details.

Rear panel layout

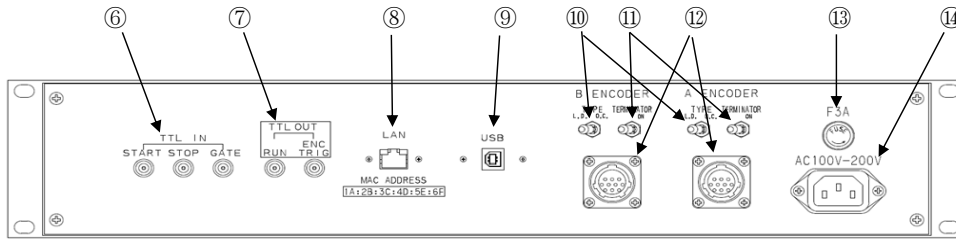

- ⑥ Connect TTL level signal (3.3 – 5V) from external unit.  
**START:** When upward edge signal is "ON" ("H"), it starts counting. (INPUT)  
 Normally (not connected) START signal is "L".  
 When count mode is selected to "Counter 07 stop" or "Timer stop" and count value or timer value goes on limit, START can't become true.  
**STOP:** When upward edge signal is "ON" ("H"), counting action stopped. (INPUT)  
 Normally (not connected) STOP signal is "L".  
**GATE:** When GATE signal goes "L", count action stopped during this level. (INPUT)  
 When it goes "H", count action starts again.  
 Normally (not connected) GATE signal is "H".
- ⑦ TTL (3.3V) output connector while counter is operating.  
**RUN:** Synchronized operation by the highest-level counter is possible by inputting it to the GATE of another module.  
 The START, STOP, GATE, and RUN signals can be logically inverted using commands.  
 By default, they are set to positive logic.  
**ENC TRIG:** Outputs an encoder synchronization pulse.  
 This signal can be used to synchronize the encoder with external devices.  
 Output polarity and output pulse width can be changed using commands.  
 The default setting is positive logic with a pulse width of 10 μs.
- ⑧ This one is ETHERNET(LAN)connection port. It's adapted to 10BASE-T,100BASE-T communication.
- ⑨ This one is USB port.
- ⑩ Select Encoder Counter type for ⑫ connector  
 L.D: Line driver      O.C: Open collector
- ⑪ Select Termination(120 Ω)
- ⑫ Input Signals from Encoder counter  
 Pannel side connector      SRCN2A16-10S(JAE)  
 Cable side connector      SRCN6A16-10P(JAE)

	1	2	3	4	5	6	7	8	9	10
Line driver	+5V	GND	(N.C)	Phase A	Phase A <sup>-</sup>	Phase B	Phase B <sup>-</sup>	Phase Z	Phase Z <sup>-</sup>	F.G
Open Collector	+5V	GND	(N.C)	Phase A	(N.C)	Phase B	(N.C)	(N.C)	Phase Z	F.G

Line driver input (in case of pin4-5. pin6-7, pin8-9 are also same)

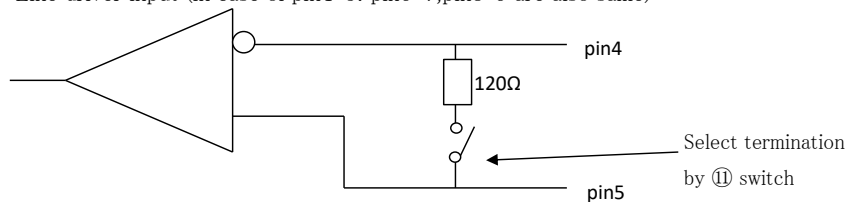

- ⑬ Fuse holder 3A(200V) mini fuse available.
- ⑭ AC90V to 240V power supply cable.

1-3. Block diagram(CT08-ER2T)

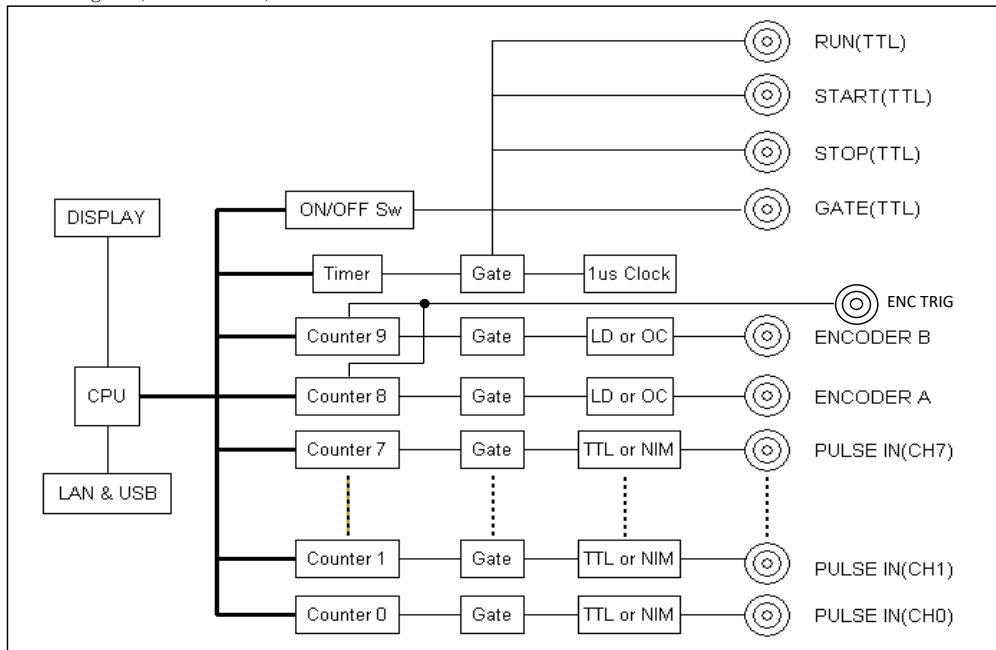

## 2.Before using

### 2-1. Select input signal level for count and read input mode settings

CT08(16)-ER2T can select count input signal mode from TTL Hi-Z, TTL 50  $\Omega$  or NIM in units of 2CH.  
TTL Hi-Z is the factory setting.

### 2-2.Setting LAN communication

#### 2-2-1.Preparation for setting

To control this one by LAN communication, it's need to some setting items by 10Base-T/100Base-T communication cable. Setting protocol is telnet protocol by TCP/IP connection.

To connect network by this one, IP address, subnet mask, and Port NO must be set to this unit.

Factory default is "IP address is 192.168.1.123", "sub net mask is 255.255.255.0" and "Port NO is 7777".

When connecting PC directly, it's need to use cross cable. Otherwise using HUB module, it's no need to use cross cable.

The way of connecting PC directly is as follows.

It's need to set IP address and subnet mask to your PC.

Set IP address to 192.168.1.10, and subnet mask to 255.255.255.0, for example.

About the way of setting address to your PC, see your PC manual.

Select MS-DOS prompt and access command "ping" in MS-DOS prompt.

```
C:\Windows>ping 192.168.1.123
```

```
Pinging 192.168.1.123 with 32 bytes of data:
```

```
Reply from 192.168.1.123: bytes=32 time=2ms TTL=255
```

```
Reply from 192.168.1.123: bytes=32 time=1ms TTL=255
```

```
Reply from 192.168.1.123: bytes=32 time=1ms TTL=255
```

```
Reply from 192.168.1.123: bytes=32 time=1ms TTL=255
```

```
C:\Windows>
```

```
If replies are listed above, physical connection is correct.
```

```
If physical connection is not correct, communication replies are these.
```

```
C:\Windows>ping 192.168.1.123
```

```
Pinging 192.168.1.123 with 32 bytes of data:
```

```
Request timed out.
```

```
Request timed out.
```

```
Request timed out.
```

```
Request timed out.
```

```
C:\Windows>
```

```
In this case please retry the connection again after confirming the cable connection.
```

#### 2-2-2.Change setting of network

Once you check connection is correct, enter new IP address and new telnet port NO of CT16-ER2T.

(If default NO is OK, you don't have to do this operation.)

Default IP address is 192.168.1.123, and default port number is 7777.

IP address must be changed according to your network system.

If a port number doesn't need change, you may use number 7777.

Let's try connecting test by optional Windows software such as "telnet".

Example test data is "telnet 192.168.1.123 7777" in MS-DOS prompt screen.

( Use default setting, or use the current setting.)

When in telnet operation, send data "VER?" which are expected reply data.

If reply data is like "1.04 15-05-19 CT08-ER2T", then communication line is right.

"Telnet" function contains hardware and software function, when disconnect line, line must be cut off by "telnet" software operation before hardware disconnection.

Next, please change IP address, port NO., Gate Way, and Sub net mask by telnet.

Change IP address :

IPAxix\_xxx\_xxx\_xxx

If you need to change IP address to 192.168.1.60, please execute the command as below.

IPA192\_168\_001\_060

Confirm IP address :

IPA?

And return is as follow.

IPA192\_168\_001\_060

Change port number :

PRTxxxx

If you need to change port number to 10999, please execute the command as below.

PRT10999

Confirm port number :

PRT?

And return is as follow.

PRT 10999

If need, you can change sub net mask, and Gate Way address.

After the above changes, CT48-01E is working with new setting, if the one of three is executed.

- Send the command "RSET"
- Push RES/FWR switch 1sec at the front panel
- Power off, and power on after few seconds.

When LAN setting such as IP address became unknown, a setting change by LAN is not possible.

In that case, using USB communication at section 2-3, you can confirm and change.

#### 2-2-3.Turn back PC set data

When PC settings were changed, move to the initial PC settings.

#### 2-2-4.Connecting test

Let's try connecting test by optional Windows software such as "telnet".

Example test data is "telnet 192.168.1.123 7777" in MS-DOS prompt screen.

(IP address number must to be set number preliminary. )

When in telnet operation, send data "VER?" which are expected reply data.

If reply data is like "1.04 15-05-19 CT08-ER2T", then communication line is right.

"Telnet" function contains hardware and software function, when disconnect line, line must be cut off by "telnet" software operation before hardware disconnection.

## 2-3.Setting USB communication

### 2-3-1.Preparations for setting

Driver software for USB (Universal Serial Bus) operation is downloaded from our web server.

[http://www.tsuji-denshi.co.jp/download\\_file/YS\\_USBCOM.EXE](http://www.tsuji-denshi.co.jp/download_file/YS_USBCOM.EXE)

By installing this software, connecting is done like a COM port connection.

Switch on a CT48-01E, connect USB cable, then there will be message box that shows "New hardware device was found (CDC-RS232)". According to PC directions, specify 'the folders of downloaded driver software.

When the driver software installs are done, open the "Control Panel" ( START → Control Panel), click the "System" icon. Then property display of system appears. Select the "Device Manager".

Confirm the USB Serial Port (Com\*) number in the tree between Port display.

You can see like "YS USB COM Port (COM5)" in port "COM and LPT" in tree.

Select the USB Serial Port (Com\*), click Advanced in Port Setting display. It's possible to change COM Port number. Click the check box Disable PNP  , it's possible to short operation time in connecting USB cable again.

You don't need to change RS232C setting like baud rate.

### 2-3-2. Connecting test

Launch RS-232C communication software such as hyper-terminal including PC.

Set COM port number which is known in previous item, it's need to check communication line is available or not. In this case It's no need to set baud rate. Send the command data such as "VER?", then get the reply "1.04 15-05-19 CT08-ER2T", there is no problem for communication.

## 2-4.Connect communication cables

### 2-4-1.Connect communication cables

Connect the communication cable to USB port or LAN port on rear panel.

There is no need to connect both side, but there will be no problem even if connect both side.

If connected both side, latest command will be valid to the unit.

The Counter accepts 8 LAN connections at the same time.

However, only one connection is available regarding download.

During download, there is no reply message for the speed improvement.

But, the Counter accepts the command to stop download.

During high speed download (hexadecimal download), it may be unable to stop in the middle of run.

Because, the Counter is busy to receive data, and the software may be unable to send the stop command from the same line. (It becomes easy to occur when COMM monitor is being displayed.)

In this case, you can send the stop command via other software and other LAN/USB port, and stop the Counter.

#### 2-4-2. Setting and reading the count input signal level

The CT08(16)-ER2T allows you to select the count input signal from TTL Hi-Z, TTL 50 Ω, or NIM level. It is shipped in TTL Hi-Z mode.

Type of command

THI ALL	Sets the input mode of all channels to TTL Hi-Z.
Response: OK	
THI x	Sets the input mode of the specified channel x (0, 2, 4, ..., 14) and x+1 to TTL Hi-Z.
Response: OK	
T50 ALL	Sets the input mode of all channels to TTL 50 Ω.
Response: OK	
T50 x	Sets the input mode of the specified channel x (0, 2, 4, ..., 14) and x+1 to TTL 50 Ω.
Response: OK	
NIM ALL	Sets the input mode of all channels to NIM.
Response: OK	
NIM x	Sets the input mode of the specified channel x (0, 2, 4, ..., 14) and x+1 to NIM.
Response: OK	
IN? xx	Reads the input mode.

Example response:

```
CH 00 - 07 : TTL_Hi TTL_Hi TTL_50 TTL_50 NIM NIM TTL_50 TTL_50
```

Connect the signals to be counted to the LEMO connectors CH0-CH15 on the front panel.

Up to 8-16 channels of signals can be counted simultaneously.

You must select the appropriate input signal using commands according to the signals you want to count.

#### 2-4-3. Connect count signal

Connect count signal cable to CH0 ~ 15 LEMO connector which are on front panel. It's possible to count maximum 16 channel signals.

#### 2-4-4. Start signal (TTL positive logic)

TTL positive logic signal starts counting action.

The width of start signal pulse must be more than 100ns.

If pulse width is long, please set to "L" before next stop.

It's possible to check the count start status by LED lamp on front panel.

It counts from start signal "ON" to stop signal "ON".

When the start signal is not used, it's possible to start by software commands.

#### 2-4-5. Stop signal (TTL positive logic)

TTL positive logic signal quits counting action.

The width of stop signal pulse must be more than 100ns.

If pulse width is long, please set to "L" before next start

It's possible to check the count stop status by LED lamp on front panel.

It counts from start signal "ON" to stop signal "ON".

When the stop signal is not used,, it's possible to quit counting by software commands.

#### 2-4-6. Gate signal (TTL positive logic)

Gate signal is TTL positive logic signal.

When gate signal goes "L" counting action stopped during "L" period. \*)

When gate signal goes "L" LED lamp is "OFF" during this period.

LED lamp goes "ON" during gate signal is "H" when counter starts.

When gate signal is no connection, gate signal is equal to logic "H", because of internal pull-up.

When gate signal has been changed to "OFF", the count data are stored in memory on synchronous gate data acquisition mode.

Memory size is about 5MB. Data can be stored up to 30,000 memory addresses for CT08 type, and stored up to 15,000 memory addresses for CT16 type.

\*) On synchronous gate edge data acquisition mode, the counting action continues to work, even if gate signal goes "L".

#### 2-4-7. Monitor out signal (In counting, TTL positive logic)

Run signal goes "H" when counting action is valid. It means count start and "Gate signal" are in "H" logic, and LED goes "ON".

It's useful to use more than two counter units. Connecting this line to "Gate signal input" of another unit, another units go active counting action.

Please see the section "8. Synchronous drive of multi units" for more details.

You can adjust pulse width, if the signal is difficult to use as trigger for other equipment because of narrow width ( $<10 \mu s$ ).

### 3.Communication commands

#### 3-1.Communication commands

Command characters are ASCII data.

The delimiter of communication command is CR+LF in transmit and receive case.

In "all reply modes", CT16-ER2T replies "OK" or "NG",

even if the command doesn't require a reply. Please see the section 3-7.

#### 3-2. Read-out commands for counter set and the status of setting

##### 3-2-1. Stop enable by count value

Type of command

ENCS

Enable to stop count by counter(CH7).

Also, memorized to ROM.

When count value of preset channel (CH7) reach to preset value, count action automatically stopped.

On synchronous gate data acquisition mode, this command will be ignored.

##### 3-2-2. Stop enable by timer value

Type of command

ENTS

Enable to stop count by timer.

Also, memorized to ROM.

When timer value reach to preset timer value, count action automatically stopped.

On synchronous gate data acquisition mode, this command will be ignored.

##### 3-2-3. Stop disable by counter timer

Type of command

DSAS

Disable to stop count by counter (CH7) or timer.

Also, memorized to ROM.

Counter doesn't stop automatically.

To quit counter action, it's valid for "STOP" command or "STOP" input signal (TTL Level) or meet the condition of stopping GATE data acquisition mode.

##### 3-2-4. Inquiry of action mode

Type of command

MOD?

The latest counter mode is read.

Reply

R\_SN\_T\_O

R: remote mode (fixed)

SN: single mode (fixed)

T: T/timer stop mode, C/counter stop mode, N/not stop mode

(When power switch on, the last mode is memorized)

O: O/counter On, F/counter off

(When power switch on, count function is "OFF".)

##### 3-2-5. Setting and readout of preset counter

Type of command

SCPRdddd••••

To set preset value dddd••••• in decimal to preset counter.

Unit is Kcts.

Maximum value is 4,294,967 Kcts.

SCPRFdddd••••

To set preset value dddd••••• in decimal to preset counter.

Unit is cts.

Maximum value is 4,294,967,295 cts.

Type of command	
CPR?	To read out preset count value.
Reply	
0001000	Reply data is 8 digit decimal value. (Kcts unit)
CPRF?	To read out preset count value.
Reply	
0001000	Reply data is 8 digit decimal value. (cts unit) (If reply data is over 8 digit, the digit is as the count digit.)

### 3-2-6. Setting and readout of preset timer

Type of command	
STPRdddd••••	To set preset value dddd••••• in decimal to timer. (ms unit) Maximum timer set value is 1,099,511,627 ms.
STPRFdddd••••	To set preset value dddd••••• in decimal to timer. ( $\mu$ s unit) Maximum timer set value is 1,099,511,627,776 $\mu$ s.

Type of command	
TPR?	To read out preset timer value.
Reply	
0001000	Reply data is 8 digit decimal value. (ms unit)
TPRF?	To read out preset count value.
Reply	
0001000	(If reply data is over 8 digit, the digit is as the timer digit.)

### 3-3. Commands of counter operation

#### 3-3-1. Counter start

Type of command	
STRT	Enable counter start.

#### 3-3-2. Counter stop

Type of command	
STOP	Enable counter stop. Synchronous gate data acquisition is ended compulsorily.

#### 3-3-3. Gate in enable/disable

Gate is always made to an on-state, without desorbing a Gate connection cable.

This function is available from "HD-VER 4" or later.

Confirmed the hardware version by the command "VERH?"

Please ask us about Hardware version up.

Type of command	
GATEIN_DS	Gate is always turned ON. A counting can be started irrespective of the Gate status. Gate synchronous data acquisition cannot be done in this status.
GATEIN_EN	GATE input becomes effective, according to an input state, it becomes possibility of a counting, or prohibition. GATE signal synchronism data acquisition is possible in this status. After power-up, Gate Function is this mode.
GATEIN?	Ask GATE input status. GATE function is enable, when the reply is EN. GATE function is disable, when the reply is DS.

3-4. Read-out and clear commands for counter and timer

3-4-1. Read-out and clear commands for all counter and timer

Type of command

RDAL? To read all counter channels and timer

Reply example

1234567890 2345678901 3456789012 ..... 0123456789

These data are 10 digit number in decimal.

The data order is CH0 CH1 CH2 ..... CH7 timer.

Unit is cts for counter and  $\mu$  s for timer.

Type of command

RDALH? To read all counter channels and timer in hexadecimal.

Reply example

1DC2829F 07C38528 0451EEC3 106D8230 ..... 00FFE101 000161C602

These data are 8 digit in hexadecimal.

The data order is CH0 CH1 CH2 ..... CH7 timer.

Units of counter is cts and timer is  $\mu$  s.

Type of command

CLAL To clear all counter channels and timer

3-4-2. Read-out and clear commands for all counter

Type of command

CTR?xx To read count value of channel number xx.

CTR?xyy To read count value from channel number xx to channel number yy.

Reply example

1234567890 Reply data is 10 digit data in decimal. Unit is cts.

1234567890 2345678901 3456789012 ..... 0123456789

Reply data is 10 digit data in decimal in order. Unit is cts.

Type of command

CTRH?xx To read count value of channel number xx in hexadecimal.

CTRH?xyy To read count value from channel number xx to channel number yy in hexadecimal.

Reply example

1DC2829F Reply data is 8 digit in hexadecimal. Unit is cts.

1DC2829F 07C38528 0451EEC3 106D8230 ..... 00FFE101

Reply data is 8 digit in hexadecimal in order. Unit is cts.

Type of command

CLCTxx To clear the count value of counter channel xx.

CLCTxyy To clear the count value from counter channel xx to channel yy.

CLPC To clear the count value of preset counter channel 07.

3-4-3. Read-out and clear commands for timer and setting reading

Type of command

TMR? To read timer value.

Reply example

1234567890

Reply data is 10 digit data in decimal. Unit is  $\mu$  s.

Type of command

TMRH? To read timer value in hexadecimal.

Reply example

000161C602

Reply data is 8 digit in hexadecimal. Unit is  $\mu$  s.

Type of command

CLTM To clear timer value.

Type of command

CTMR?uuvvww The current value of the specified counter timer is read with a decimal number.

counter: uu ~ vv ch timer: ww/01 with read ww/00 without read

Reply example

1234567890 1234567890 1234567890 1234567890 1234567890 1234567890

Reply with 10 characters of decimal numbers .

counter: cts unit, timer  $\mu$  s unit

Type of command

CTMRH?uuvvww The current value of the specified counter timer is read with a hexadecimal number.

counter: uu ~ vv ch timer: ww/01 with read ww/00 without read

Reply example

1DC2829F 07C38528 0451EEC3 106D8230 ..... 00FFE101

Reply with 8 characters of hexadecimal numbers .

counter: cts unit, timer  $\mu$  s unit

3-4-4. The continuation read of the synchronous timer counter by an internal timer

At the fixed interval specified beforehand, a specified timer counter is read continuously.

Type of command

TSDL(H)uvw

The details of the timer synchronous download is specified.

If H is attached, a data will be acquired with a hexadecimal number.

If H is not attached, a data will be acquired with a decimal number.

(Timer Synchronous DownLoad)

u: 0 - 7 / top counter channel                      v: 0 - 7 / end counter channel

Read out data from ch u to ch v.

If u => v, read out data from the counter u.

w: 0 / without timer data                      w: 1 / with timer data

Send example

"TSDL071"

Download data from the counter ch 0 to ch7 and the timer.

"TSDL770"

Download data from only the counter ch 7.

"TSDLH071"

Download a hexadecimal data from the counter ch 0 to ch7 and the timer.

"TSDLH770"

Download a hexadecimal data from only the counter ch 7.

TSDLX(H)uuvvww

The details of the timer synchronous download is specified.

If H is attached, a data will be acquired with a hexadecimal number.

If H is not attached, a data will be acquired with a decimal number.

(Timer Synchronous DownLoad)

uu: 00 - 63 / top counter channel

vv: 00 - 63 / end counter channel

Read out data from ch uu to ch vv.

If uu => vv, read out data from the counter uu.

ww: 00 / without timer data

ww: 01 / with timer data

Send example

"TSDLX004701"

Download data from the counter ch 0 to ch47 and the timer.

"TSDLX474700"

Download data from only the counter ch 47.

"TSDLXH004701"

Download a hexadecimal data from the counter ch 0 to ch47 and the timer.

"TSDLXH070700"

Download a hexadecimal data from only the counter ch 7.

Type of command

TSDTxxx

Timer synchronous interval time is specified per 1 ms.

xxx: Interval value of 1 ms units

Send example

"TSDT001"

Interval value is 1ms.

xxx is specified from 001 to 9999.

Type of command

TSDT?

Ask timer synchronous interval time.

Reply example

"010ms"

It shows the interval time is 10ms.

Type of command

TSDSTRT

To the specified timing, A continuation download of the specified details is started.

Type of command

TSDSTOP                      Stopped a timer synchronous continuation download.  
STOP                            Stopped a counter and a timer synchronous continuation download.

Decimal number download type

1234567890  
1234567890 2345678901 3456789012 ..... 0123456789  
Returned in order with 10 figures of decimal numbers.  
If 10 figures is exceeded, it will be extended automatically.  
A counter is a cts unit of measure.

Hexadecimal number download type

1DC2829F1234  
1DC2829F5678 07C385289ABC 0451EEC3DEF1 106D82302345 ..... 00FFE101  
Returned in order with 12 figures of hexadecimal numbers.  
And returned in order with 10 figures of hexadecimal numbers.  
A counter is a cts unit of measure.

Example of a continuation read command sending of a Timer Counter

- 1) "TSDLH671"                      Specified to read a counter from ch6 to ch7 and a timer
- 2) "TSDT010" or "TSDT10"        Set the read out interval to 10ms.
- 3) "TSDSTRT"                      Start to read out.
- 4) "CLAL"                          Clear the timer and all of the counters.
- 5) "DSAS"                          Disable a stop of a counter and a timer.
- 6) "STRT"                          Start to count.
- 7) "TSDSTOP"                      Stopped a continuation download.
- 8) "STOP"                          Stop a counter.

TSDLH671, "TSDT010", etc. must be executed before the above command 3) "TSDSTRT".  
The command is saved once it executes.  
It is okay "STRT" command is executed before "TSDSTRT" or later.

The quantity of a data and the specification of a read interval which are downloaded each time,  
A data may be missing with the velocity of a communication line.  
Please take into consideration "Data read time" of the section 4-5-7.

### 3-4-5. The continuation read of the synchronous timer counter by the external gate input

It is an interval in synchronization with an external-gate input timing, a specified timer counter is read continuously.

Type of command

XSDL(H)uvw                      The details of an external-gate input synchronous download are specified.  
If H is attached, a data will be acquired with a hexadecimal number.  
If H is not attached, a data will be acquired with a decimal number.  
(eXternal Synchronous DownLoad)  
u: 0 - 7 / top counter channel                      v: 0 - 7 / end counter channel  
Read out data from ch u to ch v.  
If u => v, read out data from the counter u.  
w: 0 / without timer data                              w: 1 / with timer data

Send example

"XSDL071"                      Download data from the counter ch 0 to ch7 and the timer.  
"XSDL770"                      Download data from only the counter ch 7.  
"XSDLH071"                      Download a hexadecimal data from the counter ch 0 to ch7 and the timer.  
"XSDLH770"                      Download a hexadecimal data from only the counter ch 7.

XSDLX(H)uuvvww            The details of an external-gate input synchronous download are specified.  
 If H is attached, a data will be acquired with a hexadecimal number.  
 If H is not attached, a data will be acquired with a decimal number.  
 (Timer Synchronous DownLoad)  
 uu: 00 - 17 / top counter channel  
 vv: 00 - 17 / end counter channel  
       Read out data from ch uu to ch vv.  
       If uu => vv, read out data from the counter uu.  
 ww: 00/ without timer data, 01/with timer data

Send example

"XSDLX001701"    Download data from the counter ch 0 to ch17 and the timer.  
 "XSDLX171700"    Download data from only the counter ch 17.  
 "XSDLXH000701"    Download a hexadecimal data from the counter ch 0 to ch7 and the timer.  
 "XSDLXH070700"    Download a hexadecimal data from only the counter ch 7.

Type of command

XSDSTRT            A continuation download of the specified details is started synchronizing  
 with an external-gate input.

Type of command

XSDSTOP            Stopped an external-gate input synchronous continuation download.  
 STOP                Stopped a counter and an external-gate-input synchronous continuation  
 download.

Decimal number download type

1234567890  
 1234567890 2345678901 3456789012 ..... 0123456789  
       Returned in order with 10 figures of decimal numbers.  
       If 10 figures is exceeded, it will be extended automatically.  
       A counter is a cts unit of measure.

Hexadecimal number download type

1DC2829F1234  
 1DC2829F5678 07C385289ABC 0451EEC3DEF1 106D82302345 ..... 00FFE101  
       Returned in order with 12 figures of hexadecimal numbers.  
       And returned in order with 10figures of hexadecimal numbers.  
       A counter is a cts unit of measure.

Example of a continuation read command sending of a Timer Counter

- 1) "XSDLH671"            Specified to read a counter from ch6 to ch7 and a timer
- 2) "XSDSTRT"            Start to read out. A gating input turns into a timing input  
                           signal by this command
- 3) "CLAL"                Clear the timer and all of the counters.
- 4) "DSAS"                Disable a stop of a counter and a timer.
- 5) "STRT"                Start to count.
- 6) "XSDSTOP"            Stopped a continuation download.
- 7) "STOP"                Stop a counter.

XSDLH671, "XSDT010", etc. must be executed before the above command 2) "XSDSTRT".

The command is saved once it executes.

It is okay "STRT" command is executed before "XSDSTRT" or later.

The quantity of a data and the specification of a read interval (Gate input timing) which are  
 downloaded each time, a data may be missing with the velocity of a communication line.

Please take into consideration "Data read time" of the section 4-5-7.

### 3-5. Inquiry of over-flow count data

Type of command

ALM? To inquiry about data overflow timer and count data ch0 ~ ch7

Reply example

overXXXX-- Timer is in normal.

overXXXXTM Timer is overflow.

XXXX means overflow counter channel. XXXX is 4 digit hex data.

(Example)

over0001-- It means counter CH0 is overflow. [0000 0001]

over0009-- It means counter CH0 and CH3 are overflow. [0000 1001]

over0039-- It means counter CH0,CH3, CH4 and CH5 are overflow. [0011 1001]

over000ATM It means counter CH1,CH3 and timer are overflow. [0000 1010]

over0000-- It means no overflow. [0000 0000]

Type of command

ALMX? To inquiry about data overflow timer and count data ch0 ~ ch15

Reply example

overXXXXXXXXXXXX-- Timer is in normal.

overXXXXXXXXXXXXTM Timer is overflow.

XXXX means overflow counter channel. XXXX is 4 digit hex data.

例)

over00000001-- It means counter CH0 is overflow.

over00000009-- It means counter CH0 and CH3 are overflow.

over00000039-- It means counter CH0,CH3, CH4 and CH5 are overflow.

over00000000-- It means no overflow.

### 3-6. Inquiry of software version information

Type of command

VER? To inquiry about software version information

Reply example

1.04 15-05-19 CT08-ER2T

Reply is in order, version number, date and type of the unit.

Type of command

VERH? To inquiry about hardware version information

Reply example

HD-VER 1 Reply is in order, "HD-VER", version number.

### 3-7. Other commands

1) All reply mode : Command return "O. K" or "NG", when a command is not required to response

As for the command without responses, such as "ENTS" and "ENCS", it was unknown whether the command had arrived. By executing the following commands, you can confirm whether a command is handled by a reply of "OK" and "NG". NG is returned when not analyzed correctly.

Regarding the case of "OK", it shows that the processing has been advanced. And, this is not the evidence that the command is working correctly or not.

Please use this mode for "debug" of the communications (LAN, USB).

Type of command

ALL\_REP\_EN Right after "all reply mode" has been activated, the reply is "OK" or "NG" even if the command doesn't require a reply. And after receive this command, there is a reply "OK".

Type of command

ALL\_REP\_DS            There is not reply, if the command doesn't require a reply.

Type of command

ALL\_REP?            Read "all reply mode" setting.  
                      The mode is active, if the answer is "EN".  
                      The mode is not active, if the answer is "DS".

## 2) Command to read internal flag of counter

Type of command

FLG?0 FLG?1 FLG?2 FLG?3

The status of 8 bits of internal flags is returned with the hexadecimal of double figures.

Reply for command "FLG?0"

Reply data "04" mean "Counter number 2 overflow".

b7:  
b6:  
b5:  
b4:  
b3: Counter number 3 overflow  
b2: Counter number 2 overflow  
b1: Counter number 1 overflow  
b0: Counter number 0 overflow

Reply for command "FLG?1"

Reply data "04" mean "Counter number 6 overflow".

b7:  
b6:  
b5:  
b4:  
b3:  
b2: Counter number 6 overflow  
b1: Counter number 5 overflow  
b0: Counter number 4 overflow

Reply for command "FLG?2"

b7:  
b6: RUN OUT  
b5: COUNTER ON  
b4: Timer overflow  
b3: Counter number 7 overflow  
b2: TTL GATE  
b1: TTL STOP  
b0: TTL START

Reply for command "FLG?3"

b7:  
b6:  
b5:  
b4:  
b3:  
b2: Gate Edge mode ON  
b1: Timer Gate mode ON  
b0: Gate mode ON

#### 4. Counter data acquisition commands for internal RAM

##### 4-1. About counter data acquisition commands

These commands help you to store the count data changing from moment to moment.

There are two timings of storing counter data, one is through GATE signal, the other is internal TIMER.

As the following figure shows, the data which increased input pulse in count time are stored sequentially in memory.

##### (GATE MODE)

Counts while GATE signal is H, and count data is stored on the memory (\*) at falling edge.

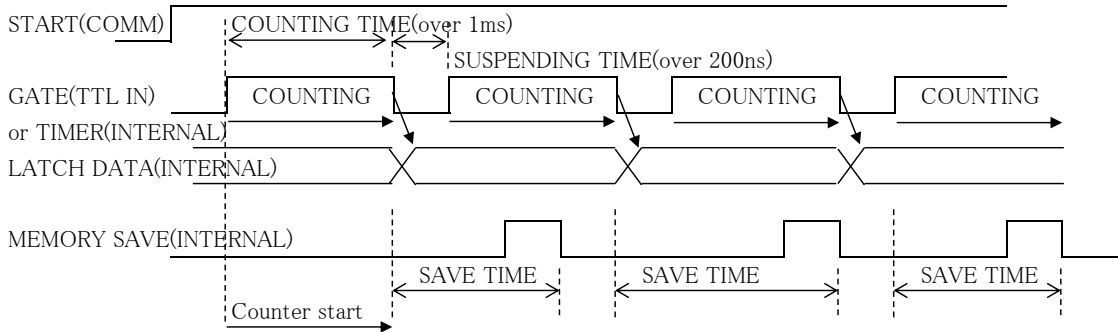

To meet the condition of  $\text{SAVE TIME} \geq 1\text{ms}$ ,  
please input  $\text{COUNTING TIME} + \text{SUSPENDING TIME} \geq 1\text{ms}$ .

##### (GATE EDGE MODE)

Count data is stored on the memory (\*) at the falling edge of GATE signal.

Counter starts at the first falling edge of GATE signal after STRT command. And the Counter continues to count, even if GATE signal is "L".

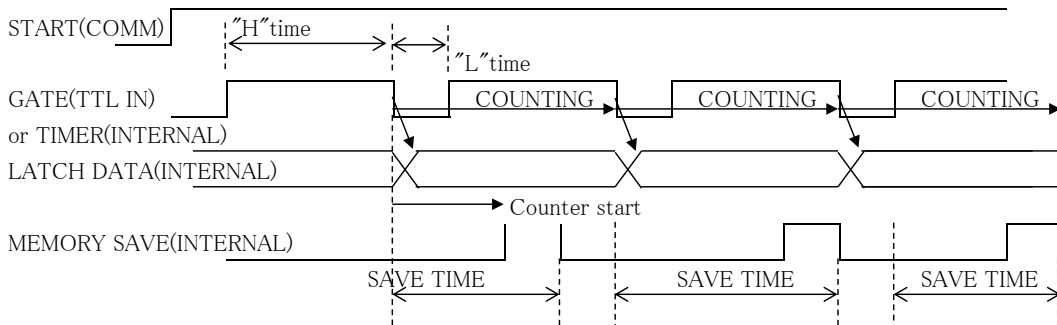

To meet the condition of  $\text{SAVE TIME} \geq 1\text{ms}$ ,  
please input  $\text{"H" TIME} + \text{"L" TIME} \geq 1\text{ms}$ .

(\*) Internal memory size is about 5MB. Therefore, numbers of channels differ depending on the model of a counter, and the numbers of data which can be saved differ.

CT08-ER2T:30000、CT16-ER2T:15000

##### 4-2. Preparation for data acquisition commands

Data are stored on memory(Address:0~14999 or 29999)

You can set up acquisition starting data address and end.

Data acquisition stops automatically if current data address reach the acquisition end data address.

You can read current data acquisition address.

#### 4-2-1. Clear current data address

Type of command

CLGSDN                      Clear current data address.  
Set data acquisition starting address to zero.

#### 4-2-2. Clear current data address and all stored data

Type of command

CLGSAL                      Clear current data address and all memory data.  
Set data acquisition start address to zero and clear all memory data.  
It takes 30 sec to complete the command.  
Please be careful, it is not possible to communicate until the command finishes.  
Current data is overwritten even if it does not clear all the data.

#### 4-2-3. Set and read gate synchronous data acquisition current data address

Type of command

GSDNddd...                Set current data address with a decimal value.  
ddd... : 0 ~ 9999

Type of command

GSDN?                      Read out current data address.

Reply

0 ~ 9999

#### 4-2-4. Set and read gate synchronous data acquisition end data address

Type of command

GSEDddd...                Set acquisition end data address.  
Data acquisition stop automatically if current data address reach end address.

Type of command

GSED?                      Read data acquisition end address.

Reply

0 ~ 14999 or 29999              Reply on a decimal value.

#### 4-2-5. Setting of an accumulated data acquisition and an increment data acquisition

It can choose whether to record the data to collect with a raw counting value (accumulation value), or to collect increment data.

When Power-up, the accumulation value is chosen.

Type of command

GT\_ACQ\_DIF                Increment data are collected.  
It is the difference data which subtracted the last counter value from the present counter value.

Type of command

GT\_ACQ\_FUL                Accumulation values are collected. When power-up, this mode is chosen.  
The value of the read counter becomes a data as it is.

Type of command

GT\_ACQ?                    The data to collect asks a raw counting value or increment.

Reply

FUL: A raw counting value              DIF: Increment counting value

#### 4-3. Synchronous GATE signal data acquisition commands

Type of command

GSTRT Start to store gate synchronous data. (Just after turn on power, it's stop condition)  
Entering this command after preparation of section 4-2, CT16-ER2T starts data acquisition synchronized gate signal.  
It stores signal data from current data address to end data address synchronized by Gate signal.  
Inputting "STOP" command, data acquisition stops immediately.

Type of command

GESTRT Start to store gate edge synchronous data. (Just after turn on power, it's stop condition)  
Entering this command after preparation of section 4-2, counter gate opens at the first falling edge of gate signal, CT16-ER2T starts synchronous falling edge of gate signal data acquisition.  
  
It stores signal data from current data address to end data address synchronized by falling edge of Gate signal.  
Inputting "STOP" command, data acquisition stops immediately.

#### 4-4. Synchronous internal clock data acquisition commands

In this mode, data acquisition is synchronized by clock generated by CT16-ER2T.

It's necessary to preset the value of clock ON time and clock OFF.

External gate input signal works gate signal during data acquisition operation.

If you're going to store data synchronized clock gate signal only, please set gate signal to ON.

(GATE ON = input OPEN:positive /Default setting is positive.)

##### 4-4-1. Set and read synchronous Timer RUN time

Type of command

GTRUNddd... Set synchronous timer data RUN time  
(1  $\mu$ s ~ 4,294,967,295  $\mu$ s :  $\mu$ s units.)  
To make sure of time enough to store data, it's recommended that the sum of gate RUN time and STOP is over 10,000(=10ms).

GTRUN? Read synchronous timer data RUN time

Reply

20000 Read by  $\mu$ s units. Ex. 20,000 = 20ms

##### 4-4-2. Set and read synchronous timer OFF time

Type of command

GTOFFddd... Set timer synchronous data STOP time  
(1  $\mu$ s ~ 4,294,967,295  $\mu$ s :  $\mu$ s units. If you input 0, set about 200ns.)  
To make sure of time enough to store data, it's recommended that the sum of gate RUN time and STOP is over 10,000(10ms).

Type of command

GTOFF? Read the timer synchronous data STOP time

Reply

20000 Read  $\mu$ s units. Ex. 20,000 = 20ms

4-4-3. Start synchronous timer clock data acquisition

Type of command

GTSTRT Start to store clock synchronous data.  
 (Just after turn on power, it's stop condition)  
 Entering this command after preparation of section 4-2-1~3 and 4-3-1~2, CT16-ER2T starts synchronous clock signal data acquisition.  
 It stores signal data from current data address to end data address synchronized by clock signal.  
 Inputting "STOP" command, data acquisition stops immediately.

4-5. Common commands on synchronous data acquisition

These are common commands both in GATE synchronous data acquisition and in inner TIMER.

4-5-1. Counter stop

Type of command

STOP Stop counting immediately.  
 Data acquisition for synchronous GATE signal and internal timer also stops.

4-5-2. Read out the status of synchronous gate data acquisition

Type of command

GSTS? Read out the data acquisition status.

Reply

Gate mode ON Data acquisition on gate mode.  
 Timer Gate mode ON Data acquisition on timer gate mode.  
 Gate Edge mode ON Data acquisition on gate edge mode.  
 Now Hex Conversion When the data is converted to hexadecimal number (the conversion for high speed read), if data are acquired in the interval of 1ms~10ms, the hexadecimal number conversion for high speed read does not meet to the end of data acquisition. And this message is outputted to an enquiry till the completion of a translation after data acquisition completion.  
 Gate mode OFF Gate mode is not active.

4-5-3. Read out all stored data(0~current data address)

Type of command

GSDAL? Read out all stored data from 0 to current data address.  
 Current data address is set the next address to end data address just after data acquisition. Read out ch0~ch7.

	ch0	ch1	ch2	.....	ch7	timer	
Reply example:	00123,	00456,	07890,	.....	, 01234,	234567	← Data of No.0
	00123,	00456,	07890,	.....	, 01234,	234567	← Data of No.1
	.....						
	00123,	00456,	07890,	.....	, 01234,	234567	← Data of No.n(n:acquisition end)

Data are output in order counter ch0 to ch7 and timer on one line.  
 Each data is output at 5 digits added 0 on head if the number of digit is below 5.  
 If over 5, each data is output at maximum digits of them.

Type of command

GSDALX? Read out all stored data from 0 to current data address.  
 Current data address is set the next address to end data address just after data acquisition. Read out ch0~chX-1. X:16

	ch0	ch1	ch2	.....	ch31	timer	
Reply example:	00123,	00456,	07890,	.....	, 01234,	234567	← Data of No.0
	00123,	00456,	07890,	.....	, 01234,	234567	← Data of No.1
	.....						
	00123,	00456,	07890,	.....	, 01234,	234567	← Data of No.n(n:acquisition end)

Data are output in order counter ch0 to chX-1 and timer on one line.  
 Each data is output at 5 digits added 0 on head if the number of digit is below 5.  
 If over 5, each data is output at maximum digits of them.

Type of command

GSDALH?                    Read out in hexadecimal.  
                               Read out all stored data from 0 to current data address.  
                               Current data address is set the next address to end data address  
                               just after data acquisition.            Read out ch0~ch7.

	ch0	ch1	....	ch7	timer	
Reply example:	1DC2829F,07C38528,... 00FFE101,000161C602					← Data of No.0
	1DC2829F,07C38528,... 00FFE101,000161C602					← Data of No.1
	.....					
	1DC2829F,07C38528,... 00FFE101,000161C602					← Data of No.n(n:acquisition end)

Data are output in order counter ch0 to ch7 and timer on one line.  
 Counter data is 8 digit output, and timer is 10 digit output.

Type of command

GSDALXH?                    Read out in hexadecimal.  
                               Read out all stored data from 0 to current data address.  
                               Current data address is set the next address to end data address  
                               just after data acquisition.            Read out ch0~chX-1. X:16

	ch0	ch1	....	ch31	timer	
Reply example:	1DC2829F,07C38528,... 00FFE101,000161C602					← Data of No.0
	1DC2829F,07C38528,... 00FFE101,000161C602					← Data of No.1
	.....					
	1DC2829F,07C38528,... 00FFE101,000161C602					← Data of No.n(n:acquisition end)

Data are output in order counter ch0 to ch7 and timer on one line.  
 Counter data is 8 digit output, and timer is 10 digit output.

4-5-4. Read out stored data of specific range

Type of command

GSDRD?xxxxyyyy            Read out acquired data from data address of xxxx to yyyy in decimal.  
 xxxx, yyyy :When you input below 3 digits number, please put 0 on head and 4 digits.  
 Ex. GSDRD?01234567

This is an example of reading out data address from 123 to 4567.

	ch0	ch1	ch2	....	ch7	timer	
Reply example:	02123, 00456, 07890, ..... , 01234, 234567						← Data of No.123
	03123, 00456, 07890, ..... , 01234, 234567						← Data of No.124
	.....						
	04123, 00456, 07890, ..... , 01234, 234567						← Data of No.4567

Data are output in order counter ch0 to ch7 and timer on one line.  
 Each data is output at 5 digits added 0 on head if the number of digit is below 5.  
 If over 5, each data is output at maximum digits of them.

Type of command

GSDRDx?xxxxyyyy(K) Read out acquired data from data address of xxxx to yyyy in decimal.

xxxx, yyyy :When you input below 3 digits number, please put 0 on head and 4 digits.

If K is attached to an end, it expresses x1000. Please use this for 9999 or more numbers.

Ex. GSDRD?01234567

This is an example of reading out data address from 123 to 4567.

	ch0	ch1	ch2	.....	ch31	timer	
Reply example:	02123, 00456, 07890, ....., 01234, 234567						← Data of No.123
	03123, 00456, 07890, ....., 01234, 234567						← Data of No.124
	.....						
	04123, 00456, 07890, ....., 01234, 234567						← Data of No.4567

Data are output in order counter ch0 to ch31 and timer on one line.

Each data is output at 5 digits added 0 on head if the number of digit is below 5.

If over 5, each data is output at maximum digits of them.

Type of command

GSDRDH?xxxxyyyy

Read out stored data from data address of xxxx to yyyy in hexadecimal.

Type of command

GSDRDxH?xxxxyyyy(K)

Read out stored data of all ch and timer from data address of xxxx to yyyy in hexadecimal.

High-speed reading (more than 1MB/s) is possible at LAN connection.

If K is attached to an end, it expresses x1000. Please use this for 9999 or more numbers.

Type of command

GSCRD?uvwxxxxyyyy Read out stored data from data address of xxxx to yyyy.

u:read out start channel v:end channel w: if 1,read out timer data, if 0, don't read.

xxxx, yyyy :When you input below 3 digits number, please put 0 on head and 4 digits.

Ex. GSCRD?24101234567

This is an example of reading out data address from 123 to 4567 of ch2 to 4, and timer.

	ch2	ch3	ch4	timer	
Reply example:	02123, 00456, 07890, 234567				← Data of No.123
	02123, 00456, 07890, 234567				← Data of No.124
	.....				
	04123, 00456, 07890, 234567				← Data of No.4567

Data are output in order required counter (ch0 to ch7) and timer on one line.

Each data is output at 5 digits added 0 on head if the number of digit is below 5.

If over 5, each data is output at maximum digits of them.

Type of command

GSCRDX?uuvvwxxyyyyy(K) Read out stored data from data address of xxxx to yyyy.

uu:read out start channel vv:end channel ww: if 01,read out timer data, if 00, don't read.

xxxx, yyyy :When you input below 3 digits number, please put 0 on head and 4 digits.

If K is attached to an end, it expresses x1000. Please use this for 9999 or more numbers.

Ex. GSCRDX?02040101234567

This is an example of reading out data address from 123 to 4567 of ch2 to 4, and timer.

	ch2    ch3    ch4    timer	
Reply example:	02123, 00456, 07890, 234567	← Data of No.123
	02123, 00456, 07890, 234567	← Data of No.124
	.....	
	04123, 00456, 07890, 234567	← Data of No.4567

Data are output in order required counter (ch0 to ch7) and timer on one line.  
Each data is output at 5 digits added 0 on head if the number of digit is below 5.  
If over 5, each data is output at maximum digits of them.

Type of command

GSCRDH?uvvxxxxxyyy

Read out acquired data from data address of xxxx to yyyy in hexadecimal.  
This is the command for ch0~ch07.

Type of command

GSCRDXH?uuvvxxxxxyyy(K)

Read out acquired data from data address of xxxx to yyyy in hexadecimal.  
This is the command for ch0~ch31.  
If K is attached to an end, it expresses x1000. Please use this for 9999 or more numbers.

#### 4-5-5. LAN setup commands

New LAN setting becomes effective, if the one of three is executed.

- Send the command "RSET"
- Push RES/FWR switch 1sec at the front panel
- Power off, and power on after few seconds.

It continues working by old setup till the above one of three is executed.

Type of command

MAC?      Read out MAC address.

Reply example

0050C2970018      Reply is 12 digits in hexadecimal.

Type of command

IPAxix\_xxx\_xxx\_xxx      xxx: 000~255

Set IP address.

Ex. IPA192\_168\_001\_055      Set IP address to 192.168.1.55.

Type of command

IPA?      Read out P address.

Reply example

IPA192\_168\_001\_055

Type of command

PRTxxx\_xxx\_xxx\_xxx      xxx: 000~255

Set port address.

Ex. PRT 7777      Set port address to 7777.

Type of command

PRT?      Read out port address.

Reply example

PRT 7777

Type of command

GTWxxx\_xxx\_xxx\_xxx      xxx: 000~255

Set Gate Way address.

Ex. GTW192\_168\_001\_001      Set gate address to 192.168.1.1

Type of command

GTW? Read out Gate Way address.

Reply example

GTW192\_168\_001\_001

Type of command

SNMxxx\_xxx\_xxx\_xxx xxx: 000~255

Set sub net mask.

例)SNM255\_255\_255\_000

Set sub net mask to 255.255.255.0.

Type of command

SNM? Read out sub net mask.

Reply example

SNM255\_255\_255\_000

#### 4-5-6. Special commands

Important information is stored in the internal ROM.

This command can initialize the internal ROM. 'When LAN access becomes out of condition, a power supply is re-started after this command is executed by USB communication, it will be initialized.

Type of command

INITROM Initialized internal ROM as follow.

Initialization contents

IP Address : 192.168.1.123

Gateway address : 192.168.1.1

Subnet mask : 255.255.255.0

Port Number : 7777

Timer preset value : 1000ms

Counter preset value : 1,000,000

Upper display: Timer

Lower display:Counter07(preset counter)

Backlight ON

Timer Synchronous DownLoad data:ch0~ch7 & Timer & decimal

Timer Synchronous DownLoad interval:100ms

All command reply : disable

Minimum Pulse out 10  $\mu$  s : disable

Timer/Counter stop disable

4-5-7. Data read time

The read-out time of data is based on the processing time of an internal microcomputer, and the speed of the communications department. However, since this counter uses the interface to LAN, and DMA of a microcomputer, it is downloadable at high speed (a maximum of 1MB/(second) or more).

(data acquisition method)

For high-speed download, not only a raw counting data~But also a hexadecimal number conversion data is saved. If it is only raw data store, it can save at the interval for 1 ms or more.

However, the hexadecimal number conversion takes longer time (about 3.3 msec is required for 16 times of 32-bit conversion). For example of CT16-ER2T case, if 10000 data are acquired in 1 ms, a hexadecimal data is not downloadable unless it waits for about 23sec (= 3.3ms x 10,000 = 33sec) after the completion of an data acquisition (after 10 seconds). When a data is acquired every 10 ms, since a hexadecimal translation is also finished to the quit of a data acquisition, and a simultaneous, it can download immediately.

Although a status changes with a model or data volume, please take care of the data acquisition, if the interval is about 1ms.

You can confirm by the command "GSTS? (section 4-5-2)" that it is in the middle of the data conversion to hexadecimal number. If the reply of this command became "Gate mode OFF", a hexadecimal conversion was completed.

(Download commands and download speed)

Download commands are classified as follows.

(1) Download the data specified in the data address (0~9999) from all channels in hexadecimal.

GSDALXH?                    GSDRDXH?xxxxxyyy(K)

(2) Data download except (1) in hexadecimal.

GSDALH?            GSDRDH?xxxxxyyy            GSCRDH?xxxxxyyy  
GSCRDXH?uuvvwxxxxxyyy(K)

(3) Data download in decimal.

GSDAL?            GSDALX?            GSDRD?xxxxxyyy            GSDRDX?xxxxxyyy(K)  
GSCRD?uuvvwxxxxxyyy            GSCRDX?uuvvwxxxxxyyy(K)

Download Speed example

		classification1	classification2	classification3
LAN	speed	1.2MB/S	0.8MB/S	40KB/S
	time	0.8S/MB	1.3S/MB	25S/MB

		classification1	classification2	classification3
USB	speed	100KB/S	100KB/S	35KB/S
	time	10S/MB	10S/MB	28S/MB

note) CT08-ER2T (8ch type) was measured.

16ch type is faster than 8ch type.

Regarding 16ch type, 10,000 data that is about 0.85MB is downloaded about 1 sec by LAN communication. And it is downloaded about 9sec by USB communication.

5.Encorder counter

5-1.Read and Preset

5-1-1.Encorder Counter read command

Type of command

S20 chA counter read request.(the least significant 7 digit)

Reply example

RA±□□□□□□□ (□: Decimal number)

Type of command

S30 chA counter read request.(10 digit)

Reply example

RA±□□□□□□□□ (□: Decimal number)

Type of command

S22 chB counter read request.(the least significant 7 digit)

Reply example

RB±□□□□□□□ (□: Decimal number)

Type of command

S32 chA counter read request.(10 digit)

Reply example

RB±□□□□□□□□ (□: Decimal number)

5-1-2.Encorder Counter preset command

Type of command

SA±□□□□□□□□ (must be in within 10digit)

Preset chA counter

If the value is over the range,maximun(or minimum) value is set.

Type of command

SB±□□□□□□□□ (must be in within 10digit)

Preset chB counter

If the value is over the range,maximun(or minimum) value is set.

5-2.Encorder Counter setting command

5-2-1.Direction of rotation and Count UP/DOWN

Type of command

S20x Set chA encorder counter.

x: F /CW: count up、CCW:count down

R /CCW:count up、CW:count down

1 /1 times

2 /2 times

4 /4 times

Type of command

S22x Set chB encorder counter.

x: F /CW: count up、CCW:count down

R /CCW:count up、CW:count down

1 /1 times

2 /2 times

4 /4 times

### 5-2-2.Setting confirmation command

Type of command

S20S? read out chA encorder counter setting.

Reply example

1F 1 times, CW: count up  
2R 2 times, CCW:count down

Type of command

S22S? read out chB encorder counter setting.

Reply example

1F 1 times, CW: count up  
2R 2 times, CCW:count down

### 5-3.Clear Encorder Counter by Z-phase signal

Type of command

ZC□ Z-phase counter clear request

The request is cancelled by Z-phase signal input or "ZN□" command.

□:A~B (ch A~B)

Type of command

ZN□ Z-phase counter clear cancel

□:A~B (ch A~B)

Type of command

ZT□△ Select "Z-phase rising edge" or "Z-phase falling edge",to set the timing of clearing the counter.

□:A~B (ch A~B)

△:U or D (U:rise edge, D:fall edge)

(\*) When Encorder counter setting is 1times ,  
you cannot use ZT□△ command.

Type of command

ZS□ Read out Z-phase counter clear mode.

□:A~B (ch A~B)

Reply example

Z□○△

□:A~B (ch A~B)

○:C or N (C:clear mode on, N:clear mode off)

△:U or D (U:rise edge, D:fall edge)

### 5-4.Set scaling parameter

#### 5-4-1.Multiplier set command

Type of command

MW△±□□□.□□□□□□

(must be in the format)

Set scaling parameter:multiple

multiple range:±0.000001~999.999999

△:A~B (ch A~B)

□: Decimal number

Type of command

MR△ Read out scalingparameter (multiple).

△:A~B (ch A~B)

Reply example

M△±□□□□.□□□□□□

(reply is sent in the format)

△:A~B (ch A~B)

□: Decimal number

#### 5-4-2.Offset set command

Type of command

OW△±□□□□□□□□

(must be in within 10 digit)

Set scaling parameter : offset

offset range:0~±2147483647

If the value is over the range, maximum(or minimum) value is set.

△:A~B (ch A~B)

□: Decimal number

Type of command

OR△ Read out scaling paratmeter (offset)

△:A~B (ch A~B)

Reply example

O△±□□□□□□□□□□

(reply is sent in the format)

△:A~B (ch A~B)

□: Decimal number

#### 5-4-3.Scaled value read command

Type of command

D△ Read out scaled value.

△:A~B (ch A~B)

Reply example

D△±□□□□□□□□□□□□□□□□

(reply is sent in the 19 digit format. Number of decimal plases is 6.)

△:A~B (ch A~B)

□: Decimal number

5-5. Encoder Counter Synchronization Trigger Settings

Type of command

E△TE Enables the encoder counter synchronous trigger function for the selected channel.

△:A~B (chA~B)

\* When using the encoder counter synchronization trigger function, be sure to disable gate input with the GATEIN\_DS command.

Type of command

E△TD This disables the encoder counter synchronization trigger function for the selected channel.

△:A~B (chA~B)

Type of command

E△T? Reads the enabled/disabled status of the encoder counter synchronization trigger function for the selected channel.

△:A~B (chA~B)

回答例

EN Enable  
DS Disable

Type of command

E△TC±□□□□□□□□□□ (Must be no more than 10 digits)

Sets the encoder counter synchronous trigger output count for the selected channel.

△:A~B (Channels A~B)

This command generates an internal trigger edge when the encoder counter changes by the specified count.

If operating in gate edge mode, this trigger can latch the count value.

With a setting of 5, the relationship between the encoder counter and the trigger output is as follows:

Encoder count value																			
	+1	+1	+1	+1	+1	+1	+1	+1	+1	+1	+1	-1	-1	+1	+1	+1	+1	+1	+1
0	1	2	3	4	5	6	7	8	9	10	9	8	9	10	11	12	13	14	15
trigger	-	-	-	-	↑	-	-	-	-	↑	-	-	-	-	-	-	-	-	↑

Type of command

E△TC?

Reads the encoder counter synchronous trigger output count for the selected channel.

△:A~B (Channels A~B)

Reply example E△TC±□□□□□□□□□□ (□ represents a decimal number)

Type of command

E△TCC?

Reads the current value of the internal counter for the encoder counter synchronous trigger output of the selected channel.

△:A~B (Channels A~B)

The encoder counter synchronization trigger is generated by comparing the value set with the E△TC command with the counter value read by this E△TCC? command.

This internal counter is cleared when the encoder counter synchronization trigger transitions from the disabled state to the enabled state.

Reply example E△TCC±□□□□□□□□□□ (□ represents a decimal number)

Type of command

ENCTW

This command sets the encoder sync trigger output pulse width ( $\mu$  s). The setting range is 10  $\mu$  s to 1ms, and the setting resolution is 10  $\mu$  s.

(It cannot be set to 11  $\mu$  s, etc.)

This command is only effective when the encoder counter sync trigger function is disabled.

Type of command

ENCTW?

Reads the encoder synchronization trigger output pulse width setting value.

Reply example      E $\Delta$ TCC $\pm$ □□•••□□      (□ represents a decimal number)

Type of command

ENCTP

This sets the polarity of the encoder synchronization trigger output pulse.

□=POS for positive logic, □=NEG for negative logic.

Type of command

ENCTP?      Reads the polarity setting of the encoder sync trigger output pulse.

Reply example      POS or NEG

6. Abstract of LCD display

6-1. Spec of LCD display

16 characters and Two lines, LED back light (ON or OFF)

Displays "Count value: 0~4,294,967,295", "Timer value: 0~1,099,511.62s".

It can display two items from the following 4 items into the two sections (upper row and lower row) by the command via the communication line.

Count value, Timer value, Preset count value, Timer preset value

The view list items and LED back light status (on or off) are saved.

Display example 1 (upper line: count value, lower line: timer value)

C	N	T	0	1		0	0	0	0	0	0	0	0	0	
T	I	M	E	R		0	0	0	0	0	0	0	.	0	0

Display example 2 (upper line: preset count value, lower line: timer preset value)

C	N	T	P	R		0	0	0	0	0	0	0	0	0	
T	I	M	P	R		0	0	0	0	0	0	0	.	0	0

6-2. LCD display commands

Type of command

- SDU00~17 To LCD upper line, it shows one of a count value from ch0 to ch17 .  
CT08-ER2T:CH8 is Encorder A,CH9 is Encorder B.  
CT16-ER2T:CH16 is Encorder A,CH17 is Encorder B.
- SDUTM To LCD upper line, it shows a timer value.
- SDUCP To LCD upper line, it shows a preset counter value.
- SDUTP To LCD upper line, it shows a timer preset value.
- SDL00~17 To LCD lower line, it shows one of a count value from ch0 to ch17 .  
CT08-ER2T:CH8 is Encorder A,CH9 is Encorder B.  
CT16-ER2T:CH16 is Encorder A,CH17 is Encorder B.
- SDLTM To LCD lower line, it shows a timer value.
- SDLCP To LCD lower line, it shows a preset counter value.
- SDLTP To LCD lower line, it shows a timer preset value.

6-3.Backlight control commands

Type of command

- BKON Turn on the backlight
- BKOFF Turn off the backlight

6-4.Scaling function

You can use scaling function by setting scaling parameter.

Pulse counter and encorder counter is scaled by parameter (multiple , offset).

(Number of significant digits of the converted value is 15 digits)

$$\text{Scaled value} = (\text{pulse-count} + \text{offset}) \times \text{multiplier}$$

parameters are set by communication commands.

- offset 0~±2147483647 (initial data:0)
- multiplier ±0.000001 ~ 999.999999 (initial data:1)

When multiplier is 1 and offset is 0, count value is not scaled.

In other paramter, display value is integer part 3 digits, the fractional part 6 digits.

Display example 1(upper line: encorder chA scaled value, lower line: encorder chB scaled value)

E	N	C	0	0	+	9	9	9	.	9	9	9	9	9
E	N	C	0	1	-	9	9	9	.	9	9	9	9	9

Display example 1(upper line: counter ch0 scaled value, lower line: counter ch1 scaled value)

C	N	T	0	0	+	9	9	9	.	9	9	9	9	9
C	N	T	0	1	-	9	9	9	.	9	9	9	9	9

## 7. Firmware update

For CT16-ER2T it's possible to upgrade firmware via communication tools.

Here is an overview of operation.

Firmware is updated via USB communication line, and the Counter is connected with PC with USB cable.

Beforehand, please download the version up file (latest version) from HP site.

Hereafter, FLASH ROM write-in software assumes that it has prepared beforehand.

Please refer to "1st time of version up" at the last of this section, if FLASH ROM write-in software is not prepared.

### Version up procedure

1. Execute FLASH ROM write-in software "FWRITE.exe".

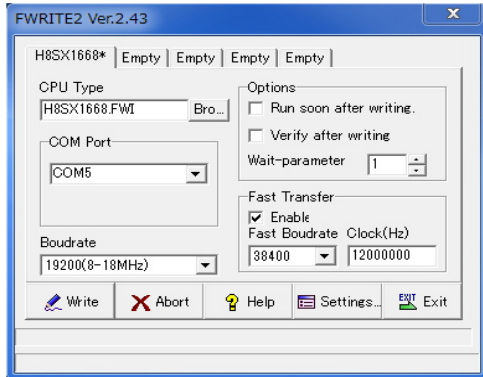

Please set up like the left window.

Please input a deemed port number to a COM port, when the USB connection is made.

Please refer to the section 2-3 for details.

2. Move to write mode.

To move to write mode, please continue pushing the button SW which is showing in the RES/FWR hole of the front panel 3 seconds or more. (The Counter will be reset, if the pushing time is shorter.)

You can judge whether it has moved to Write mode or not, if the next session (write program into ROM) is succeeded.

3. After click, to erase ROM is started. And then the file to write in is required, soon.

It takes 1 to 2 seconds to write the version up file.

4. Press the Exit button to complete write in.

Please turn off the power switch and wait 5 to 6 seconds or more. Please turn on the power switch, a new program will start. The following data beforehand are saved.

LAN data's (IP address etc.), preset values, etc.

### When updating for the first time

When the update is the first time, you need the software for writing the program into Flash ROM.

Please ask us to send the software, and we will send the software. Because, the software is not uploaded to our homepage.

USB communication must be set up to PC, and USB driver have to be installed to PC.

Please refer to "2-3. setting USB communication".

he preparation of FRASH ROM writing software.

1. Please execute FWRITE.exe that is sent from us.

The window like the below will appear.

At first, please select "H8SX1668.FWI" in "CPU type".

2. Please activate "Fast Transfer Enable", and activate "Fast Transfer Enable".

Don't need to change Boudrate 19200(8~18MHz) and Fast Boudrate 38400

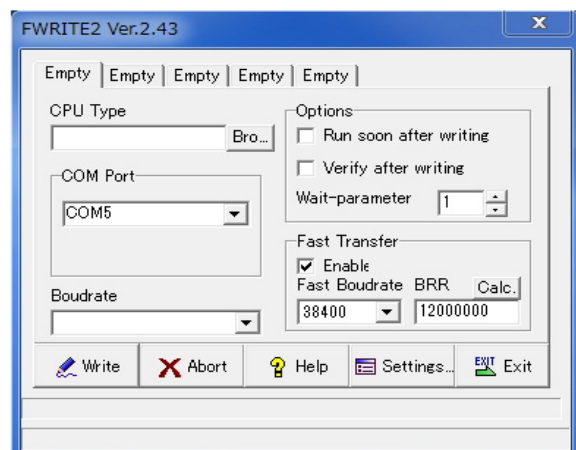

3. After the preparation, the writing software become like the picture.

The software remembers the inputs, the same inputs will appear at the next time.

Please move to the section "version up procedure 1" for update.

## 8. Synchronous drive of multi units

It's possible to operate multi units synchronously.

Then CTXX-01 contains XX CH counters, it's possible to count more channels at synchronous mode using multi units of the same series.

Here are procedures of this usage.

Connect the RUN signal (TTL OUT) of first unit to the GATE signal (TTL IN) port of second unit.

It's the same way to the third unit.

Send "DSAS" command to latter unit. The latter units don't stop counting automatically.

Send "START" command to latter unit. The latter units start counting action.

Depend on your usage, put on "GATE" signal to first unit.

Depend on your usage, preset timer stop command to first unit. ("CLTM", "ENTS", "STPRddd")

Depend on your usage, preset counter stop command to first unit. ("CLPC", "ENCS", "SCPRddd")

Activate count mode of first unit by the command "START".

This procedure activate more than one unit at the same timing chart.

Similarly, if you use several CTXX-01E, you will acquire multi channels data with gate signal data acquisition.

## 9. Designation and cancellation of RUN output TTL pulse width 10 $\mu$ s at the minimum

A RUN TTL level is outputted when the Counter is busy.

When connecting this signal to other equipment and taking a synchronous, since a pulse width is short, a reliability may be unable to be kept. For example, since the progress of the Counter is saved in the memory by internal timer synchronous, OFF time will be set to the minimum time that is 120ns, if ON time is set to 10ms and OFF time is set to 0  $\mu$  s. However, even if this signal is connected to other equipments, it may not work well because of the short pulse width. When RUN output is narrower than 10  $\mu$  s, please execute the command "MIN10U\_EN", it makes the minimum pulse width 10  $\mu$  s. MIN10U\_DS is the command to disable "MIN10U\_EN".

Please send the command "MIN10U?" to know the status, reply is "EN" or "DS".

## 10. Regulations and guidelines

Regarding CT16-ER2T when it receives data read command, it stops count and timer action for 120 ns.

This stopping period is essential to get latest data to latch 32 bits count data.

If you read out count data 20 times/sec, total stopping period of counter is  $120\text{ns} \times 20 = 2.4 \mu\text{s}/\text{sec}$ .

Even if you read one or all counter at once, all counter and timer stops simultaneously, and stopping period is always 120ns. Therefore, you may read data by minimum commands.

On timer stop mode or counter stop mode, there is no error measurement caused by counter stop on reading.

For example, a Counter has been set to stop after 1 second by timer stop mode.

If counting value read is done 10 times in 1 second, as compared with the time of not doing a readout, a timer will stop behind  $1.2 \mu\text{s}$  ( $= 120\text{ns} \times 10\text{times}$ ).

On the other hand, the Counter stopped a total of 1.2 microseconds that is the same period of the Timer.

And the Counter and the Timer has finished the action at the same time.

Therefore, it means that the counting action was done by the specified time.

When in counting pulse during "GATE" signal which comes from outside, you'll notice that counting period is shorter than read out period.

When in timer stop mode or counter stop mode, there is no dead time to read out count values.

### (※) Notes when multiple counter units at simultaneous control

(See 7. Synchronous operation by multi counter units.)

In case of using multiple counter units at simultaneous control, if you read count in progress data of each units, only units which are read count data stop count operation in 120ns.

Therefore, note that it occurs some errors among count data of modules because of condition of count pulse, timing of reading, and dispersion of times of reading.

Example: Case of reading 20 times a second to one module only

This module have  $120\text{ns} \times 10 = 1.2 \mu\text{s}$  delay in every seconds.

Count error occurs by  $1.2 \mu\text{s}/\text{s}$  (0.00012%)

11. Interface with external devices

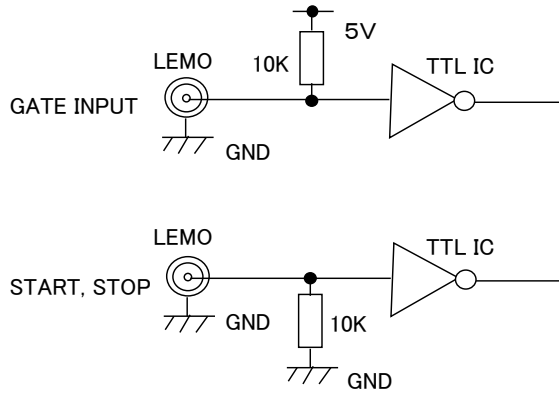

12. Regarding to remote controlled input termination switch (2019/10/29 new functionality)

Products that supports remote controlled input termination selection can use the following commands to control input termination type.

- |         |   |
|---------|---|
| IN??00  | Query termination type for channels 0 to 7.   |
| IN??08  | Query termination type for channels 8 to 15.  |
| THI?ALL | Switch all channels to TTL Hi-Z termination.  |
| THI?x   | Switch channel x (where x=0,2,4,...,14) to TTL Hi-Z termination.<br>(Channel x+1's setting will follow that on channel x)   |
| T50?ALL | Switch all channels to TTL 50 Ohm termination.  |
| T50?x   | Switch channel x (where x=0,2,4,...,14) to TTL 50 Ohm termination.<br>(Channel x+1's setting will follow that on channel x) |
| NIM?ALL | Switch all channels to NIM termination.   |
| NIM?x   | Switch channel x (where x=0,2,4,...,14) to NIM termination.<br>(Channel x+1's setting will follow that on channel x)        |

### 13. Trial Software

In Ct16-ER2T, Windows control software, which has been in use in CT08-01E will be used.

From our web site, please download and use the latest version.

If you use this software you will be able to control the CT16-ER2T from Windows PC.

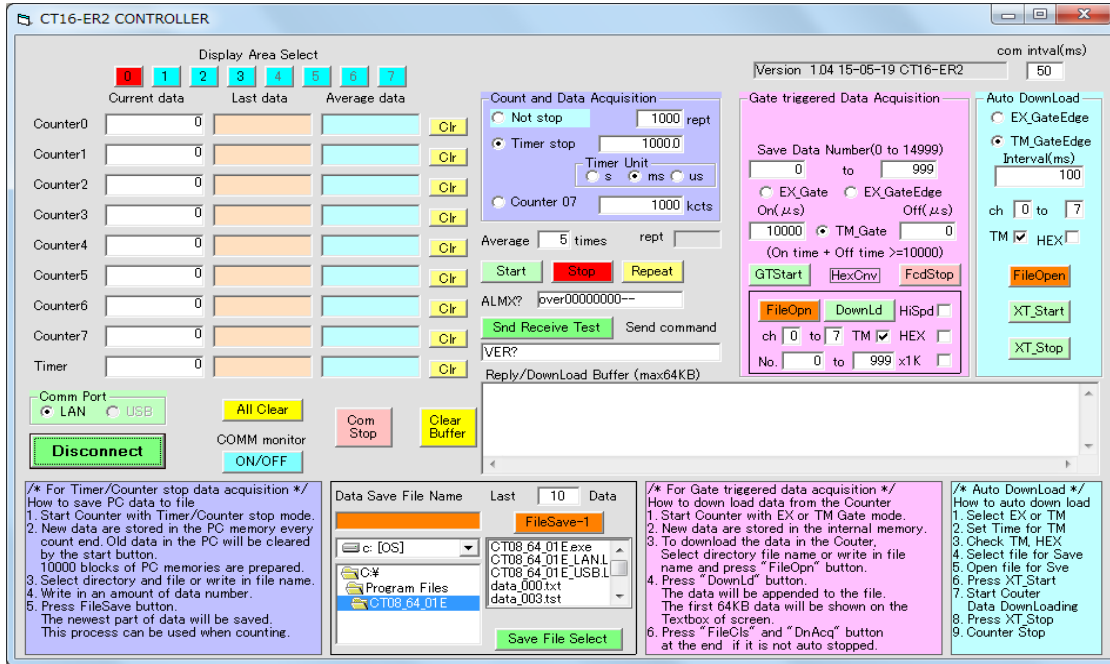

14. Performance and specifications

POWER	AC90~240V 10W	
Counter	Select input mode from TTL Hi-Z (factory setting), TTL 50 Ω and NIM level via command line.	
	TTL Input level (3.3V~5V)	Voltage level 3.3V or 5V Zin = 10K Ω or 50 Ω      Count frequency more 100MHz
	NIM Input level	Current level -12mA~-36mA:"1" -4mA~+20mA:"0" Zin = 50 Ω      Count frequency more 300MHz
	Input Connector	LEMO ERA00250CTL
	Channels	0~xxChannels (CH7 is preset counter) xx : 8, 16
	digit of count	32bits(0~4,294,967,295)
Encoder Counter	type	Line driver or Open collector ( phaseA,B type)
	input frequency	0~1MHz
	power supply	5V for encoder
	Channels	2ch (CT08-ER2T: ch8, ch9/CT16-ER2T:ch15,ch16)
	digit of count	32bit(0~4,294,967,295)
	termination	120 Ω selectable (when Line Driver type)
timer	Number of ch.	1 channel 40bit 1~1,099,511,627,775 μ s
	Resolution	0.000001sec(1 μ s) Accuracy 0.005%
	Preset time	1~ 1,099,511,627,775 μ s or ms
fixed counter	Number of ch.	1 channel CH7 Fixed
	Preset count	1cts ~ 4,294,967 Kcts or cts
Count mode	single mode	By start trigger or "STRT" command, CT08-ER2T counts input pulse once within preset time or count. Count stops immediately by stop trigger or "STOP" command. If you prohibit preset timer stop and count, count operation never stop unless using stop trigger or "STOP" command.
	gate mode	Store total data automatically up to 10,000 times on the timing of turning OFF synchronous gate signal. Over 1ms the total time of gate ON and OFF requires.
Count data acquisition mode (save to RAM)	synchronous	Store total data automatically up to 10,000 times on the timing of turning OFF synchronous clock signal. Over 1ms the total time of clock RUN and OFF requires.
	clock mode	Store total data automatically up to 10,000 times on the timing of turning OFF synchronous clock signal. Over 1ms the total time of clock RUN and OFF requires.
Gate in TTL	TTL Gate input enables count mode control with all channels and timer. Open or "H" level is count mode. You can invert logic level by inner switches. Used as a synchronous signal on gate synchronous data acquisition mode.	
LED in counting	In count mode LED turn on "green"	
Signal out in counting (RUN OUT)	TTL output shows counter is now operating. If you use some modules, you can activate them simultaneously by the highest module to connect between "TTL output" and "TTL gate in" on another module. You can invert logic level by inner switches. If the pulse width is narrower than 10us, it makes the pulse width 10 μ s.	
Control input	Count start input (by TTL rising edge), count stop input (by TTL rising edge) You can invert logic level by inner switches.	
LCD display	number of character	16 columns x 2 lines
	value	Count data, timer data, preset count data, timer preset data
	count value	0~ 4,294,967,295cts
	timer value	0~ 1,099,511.62s
scaling	Can use scaling function	
Communication	LAN(TCP/IP SOCKET CONNECTION, possible to connect 8connections), USB	
Version upgrade	upgrade firmware software by communication	
Case	EIA2U (H88*W482*D330)	

For the further information, feel free to ask us.

Tsuji Electronics Co.,Ltd.  
TEL: +81-(0)29-832-3031 FAX: +81-(0)29-832-2662  
E-mail : info2@tsuji-denshi.co.jp  
URL : <https://www.tsujicon.jp>  
3739, Kandatsu-machi, Tsuchiura-city, Ibaraki 300-0013, Japan